

NET-JRF Solution (JUNE 2019)

PART- A

- Q1. In a bacterial cell, a protein is synthesized at random location in the cytoplasm. The protein has to reach one pole of the cell for its appropriate function. The protein reaches the pole by
- (a) chemical attraction (b) random movement
(c) enzymatic action (d) attraction between opposite charges

Ans. : (b)

- Q2. A precious stone breaks into four pieces having weights in the proportion 1:2:3:4. The value of such a stone is proportional to the square of its weight. What is the percent loss in the value incurred due to breaking?

- (a) 0 (b) 30 (c) 70 (d) 90

Ans.: (c)

Solution: Weight of four pieces are $x, 2x, 3x, 4x$

Total weight of all four pieces = $10x$

The value of original piece = $100\alpha x^2$, where α is proportionality constant

Total value of pieces after breaking = $\alpha x^2 + 4\alpha x^2 + 9\alpha x^2 + 16\alpha x^2 = 30\alpha x^2$

Percentage loss in value = $\frac{70\alpha x^2}{100\alpha x^2} \times 100 = 70\%$

- Q3. Two runners starting together run on a circular path taking 6 and 8 minutes, respectively, to complete one round. How many minutes later do they meet again for the first time on the start line, assuming constant speeds

- (a) 8 (b) 24 (c) 32 (d) 60

Ans.: (b)

Solution: The required time is the LCM of 6 min and 8 min

Therefore time to meet again at the start time = 24 min

Q4. The distribution of grades secured by students in a class is given in the table below.

Grade	Fraction of the Population
A	0.1
B	0.4
C	0.3
D	0.2

What is the least possible population of the class?

- (a) 2 (b) 4 (c) 8 (d) 10

Ans.: (d)

Solution: The number of students obtaining a grade must be a whole number.

Options (a), (b) and (c) gives the number of students obtaining a grade as a fractional number. Hence option (d) is the correct answer.

Q5. The nine numbers $x_1, x_2, x_3, \dots, x_9$, are in ascending order. Their average m is strictly greater than all the first eight numbers. Which of the following is true?

- (a) Average $(x_1, x_2, \dots, x_9, m) > m$ and Average $(x_2, x_3, \dots, x_9) > m$
 (b) Average $(x_1, x_2, \dots, x_9, m) < m$ and Average $(x_2, x_3, \dots, x_9) < m$
 (c) Average $(x_1, x_2, \dots, x_9, m) = m$ and Average $(x_2, x_3, \dots, x_9) > m$
 (d) Average $(x_1, x_2, \dots, x_9, m) < m$ and Average $(x_2, x_3, \dots, x_9) = m$

Ans.: (c)

Solution: From the question

$$x_1 + x_2 + \dots + x_9 = 9m \quad (I)$$

$$\text{and } x_1 + x_2 + \dots + x_9 + m = 10\alpha \quad (II)$$

where α is the assumed average of first 9 numbers and number m

From equation (I) and (II)

$$9m + m = 10\alpha \Rightarrow \alpha = m$$

Let β be the average of x_2, x_3, \dots, x_9 . Then

$$\alpha_2 + x_3 + \dots + x_9 = 8\beta \quad (III)$$

From equations (I) and (III)

$$8\beta = 9m - x_1 = 8m + (m - x_1) \text{ or } \beta = m + \frac{m - x_1}{8}$$

Since $m > x_1$ therefore $\beta > m$

Q6. Which among the following diagrams represents women, mothers, human beings?

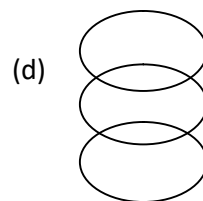
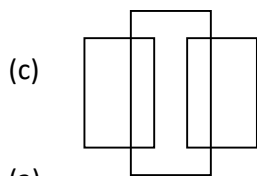
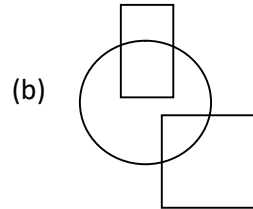
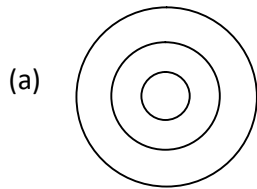

Ans.: (a)

Solution: All mothers are women and all women are human being.

Q7. A boy and a girl make the following statements, of which at most one is correct:

The one in a white shirt says: "I am a girl" (statement – I)

The one in a blue shirt says: "I am a boy" (statement – II)

Which of the following is the correct inference?

- (a) Statement – I is correct but statement – II is incorrect
- (b) Statement – II is correct but statement – I is incorrect
- (c) Both statement I and II are incorrect
- (d) The correctness of the statements I and II cannot be ascertained

Ans.: (c)

Solution: From the question, at least one statement is incorrect.

If (I) is incorrect then (II) must be incorrect and vice-versa. If we take both the statements to be incorrect this no contradiction.

Q8. How many quadrilaterals does the following figure have?

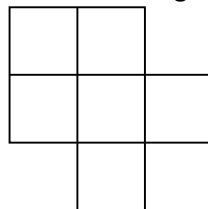

- (a) 17
- (b) 18
- (c) 19
- (d) 20

Ans.: (c)

Solution: The quadrilaterals formed are

$$1, 1+2, 1+3,$$

$$1+2+3+4, 2, 2+4$$

$$2+4+6, 3+4, 3+4+5, 4+5$$

$$4+6, 4+5+6+7, 5+7, 6+7$$

$$3, 4, 5, 6, 7$$

1	2	
3	4	5
	6	7

This total number of quadrilaterals formed are 19.

Q9. 12 balls, 3 each of the colors red, green, blue and yellow are put in a box and mixed. If 3 balls are picked at random, without replacement, the probability that all 3 balls are of the same color is

(a) $\frac{1}{4}$

(b) $\frac{1}{12}$

(c) $\frac{1}{36}$

(d) $\frac{1}{55}$

Ans.: (d)

Solution: The number of ways of drawing 3 balls is ${}^{12}C_3 = \frac{12!}{3!9!} = 220$

The number of ways of obtaining 3 balls are of the same color = 4

Hence the probability that the 3 balls are of the same color = $\frac{4}{220} = \frac{1}{55}$

Q10. Some aliens observe that roosters call before sunrise every day. Having no other information about roosters and sunrises, which of the following inferences would NOT be valid?

(a) Rooster-call and sunrise may be independent cyclic events with the same periodicity

(b) Both may be triggered by a common cause

(c) Rooster-call may be causing the sunrise

(d) Sunrise cannot be the cause of rooster call as the rooster-call precedes sunrise

Ans.: (d)

Solution: In common life we assume that cause proceeds "effect"

Q11. Twenty-one liters of water in a tank is to be divided into three equal parts using only 5, 8 and 12 liter capacity cans. The minimum number of transfers needed to achieve this is

(a) 3

(b) 4

(c) 5

(d) 7

Ans.: (d)

$21L \rightarrow 7+7+7$; Cans Capacity 5,8,12

Minimum number of transfer =7

Q12. Of four agents Alpha, Beta, Gamma and Delta, three have to be sent together on a mission. If Alpha and Beta cannot go together, Beta and Gamma cannot go together and Gamma and Delta cannot go together, then which of the following holds?

- (a) Any three agents can be sent.
- (b) Alpha, Delta and any one out of Beta and Gamma can be sent
- (c) Beta, Gamma and any one out of Alpha and Delta can be sent
- (d) The mission is impossible.

Ans.: (d)

Solution: According to the question it is impossible to form a team of 3 members as the conditions of the problem does not allow it.

Q13. An open rectangular box is made by excluding the four identical corners of a piece of paper as shown in the diagram and folding it along the dotted lines

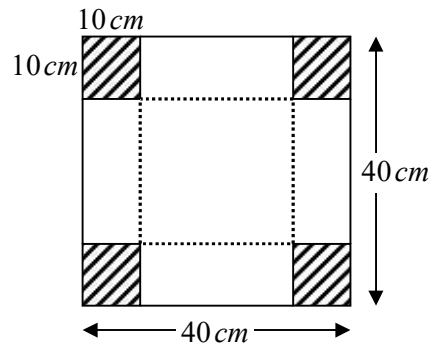

The capacity of the box (in cm^3) is

- (a) 8000
- (b) 1000
- (c) 4000
- (d) 6000

Ans.: (c)

Solution: The length and width of the box are 20 cm and 20 cm while its height is 10 cm . Hence capacity of the box is $20 \times 20 \times 10 = 4000\text{ cm}^3$

Q14. Which of the following is the largest?

$$2^{50}, 3^{40}, 4^{30}, 5^{20}$$

- (a) 2^{50}
- (b) 3^{40}
- (c) 4^{30}
- (d) 5^{20}

Ans.: (b)

Solution: $2^{50} = (2^5)^{10} = 32^{10}$; $3^{40} = (3^4)^{10} = 81^{10}$

$4^{30} = (4^3)^{10} = 64^{10}$; $5^{20} = (5^2)^{10} = 25^{10}$

Hence 3^{40} is largest

Q15. A monkey climbs a tree to eat fruits. The amount of energy gained from eating fruits and the energy spent in climbing on different branches have a relationship shown in the figure.

The ratio of energy gained to energy spent will be the maximum

- (a) at a point where the slope of the curve is the maximum
- (b) at a point where the slope of the curve is unity
- (c) at a point on the curve where the tangent passes through the origin
- (d) at the highest point on the curve

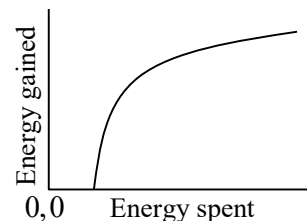

Ans.: (c)

Solution: The ratio of energy gained to energy spent will be the maximum at a point on the curve where the tangent passes through the origin.

Q16. The length of a cylinder is measured 10 times yielding 10 distinct values. For this set of values, consider the following statements

- A. Five of these values will lie above the mean and five below it
- B. Five of these values will lie above median and five below it
- C. At least one value will lie above the mean
- D. At least one value will lie at the median

Which of the statements are necessarily correct?

- (a) B and C
- (b) A and C
- (c) B and D
- (d) A, C and D

Ans.: (a)

Solution: It is not necessary that five of these values will lie above the mean and five below it. But since the observations are distinct, we can arrange them in increasing or decreasing order; hence median will be the value between 5th and 6th observation. It is the property of the mean that it must be less than the largest observation if the observations are distinct.

Q17. In the given circle, O is the centre,
 $\angle PAO = 40^\circ$, $\angle PBQ = 30^\circ$ and outer angle $\angle AOB = 220^\circ$.

Then $\angle AQB$ is

- (a) 70° (b) 80°
(c) 60° (d) 110°

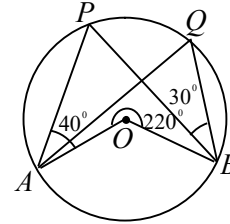

Ans.: (a)

Solution: The angle subtended by arc AMB at the circle
 $= 360 - 220 = 140$

From the fact that the angle subtended by an arc at the centre is double the angle subtended by it on the remaining part of the circle we obtain

$$\angle AQB = \frac{140^\circ}{2} = 70^\circ$$

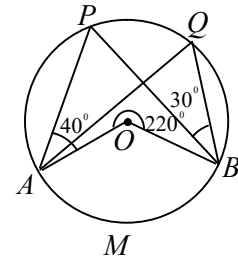

Q18. A canal system is shown in the figure

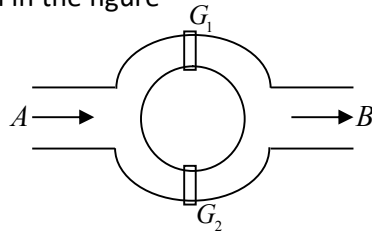

Water flows from A to B through two channels. Gates G_1 and G_2 , are operated independently to regulate the flow. Probability of G_1 to be open is 10% while that of G_2 is 20%. The probability that water will flow from A to B is

- (a) 10% (b) 20% (c) 28% (d) 30%

Ans.: (c)

Solution: Water will reach from A to B when

- (I) G_1 is open and G_2 is closed
- (II) G_1 is closed and G_2 is open
- (III) Both G_1 and G_2 are open

Hence probability that water flow from A to B is

$$0.1 \times 0.8 + 0.9 \times 0.2 + 0.1 \times 0.2 = 0.08 + 0.18 + 0.02 = 0.28 = 28\%$$

- Q19. A long ream of paper of thickness t is rolled tightly. As the roll becomes larger, the length of the paper wrapped in one turn exceeds the length in the previous turn by
- (a) t (b) $2t$ (c) πt (d) $2\pi t$

Ans.: (d)

Solution: Let r be the radius of the previous turn, then the radius of new turn will be $(r + t)$. Therefore the difference between the circumference of new turn and previous turn will

$$2\pi(r + t) - 2\pi r = 2\pi t.$$

- Q20. Point A on a wheel of radius r touches the horizontal plane at point P . It rolls without slipping, till point A is at the highest position in the first turn. What is the final distance AP ?

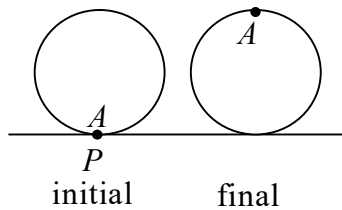

- (a) $2r$ (b) $r\sqrt{(1 + \pi^2)}$ (c) $r\sqrt{(4 + \pi^2)}$ (d) $2r\sqrt{(1 + \pi^2)}$

Ans.: (c)

Solution: When point P comes to the new position and becomes point A , the wheel makes half revolution and centre of the wheel moves by a distance πr

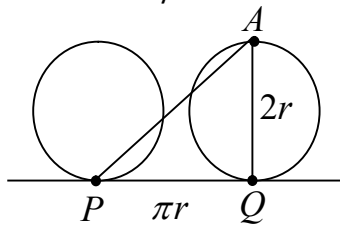

Using Pythagoras theorem in triangle APQ gives

$$AP = \sqrt{(2r)^2 + (\pi r)^2} = r\sqrt{4 + \pi^2}$$

PART- B

- Q21. An object is dropped on a cushion from a height 10 m above it. On being hit, the cushion is depressed by 0.1 m . Assuming that the cushion provides a constant resistive force, the deceleration of the object after hitting the cushion, in terms of the acceleration due to gravity g is
- (a) 10 g (b) 50 g (c) 100 g (d) g

Topic- Classical Mechanics

Subtopic- Equation of motion

Ans.: (c)

Solution: From conservation at energy

$$mgh = \frac{1}{2}mv^2 \Rightarrow v = \sqrt{20g}$$

The equation at motion when partition the cushion

$$mv \frac{dv}{dx} = mg - k$$

$$\int_{\sqrt{20g}}^0 v dv = \int_{0.1}^0 \left(g - \frac{k}{m} \right) dx \quad \frac{v^2}{2} \Big|_{\sqrt{20g}}^0 = \left(g - \frac{k}{m} \right) \times 0.1$$

$$-\frac{20g \times 0.1}{2} = \left(g - \frac{k}{m} \right) = a \quad -10g = a \quad g = a$$

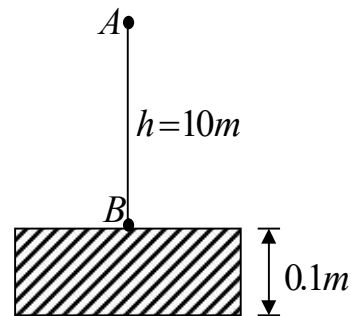

- Q22. A turn-table is rotating with a constant angular velocity ω_0 . In the rotating frame fixed to the turntable, a particle moves radially outwards at a constant speed v_0 . The acceleration of the particle in the $r\theta$ coordinates, as seen from an inertial frame, the origin of which is at the centre of the turntable, is
- (a) $-r\omega_0^2 \hat{r}$ (b) $2r\omega_0^2 \hat{r} + v_0\omega_0 \hat{\theta}$ (c) $r\omega_0^2 \hat{r} + 2v_0\omega_0 \hat{\theta}$ (d) $-r\omega_0^2 \hat{r} + 2v_0\omega_0 \hat{\theta}$

Topic- Classical Mechanics

Subtopic- Acceleration in polar coordinates

Ans.: (d)

Solution: The acceleration in Polar coordinate

$$\vec{a} = a_r \hat{r} + a_\theta \hat{\theta} = (\ddot{r} - r\dot{\theta}^2) \hat{r} + (r\ddot{\theta} + 2\dot{r}\dot{\theta}) \hat{\theta}$$

$$\dot{r} = v_0 \quad \ddot{r} = 0 \quad \text{and} \quad \dot{\theta} = \omega_0 \quad \ddot{\theta} = 0$$

$$\vec{a} = (-r\omega_0^2)\hat{r} + (2v_0\omega_0)\hat{\theta}$$

- Q23. Assume that the earth revolves in a circular orbit around the sun. Suppose the gravitational constant G varies slowly as a function of time. In particular, it decreases to half its initial value in the course of one million years. Then during this time the
- radius of the earth's orbit will increase by a factor of two
 - total energy of the earth remains constant
 - orbital angular momentum of the earth will increase
 - radius of the earth's orbit remains the same.

Topic- Classical Mechanics

Subtopic- Central motion

Ans.: (a)

Solution: $G = G(t)M \equiv$ Mass of sun, $m =$ mass of Earth

The given Problem is central force problem so angular momentum of system is conserved. $J = C$

Total Energy of system is

$$E = \frac{1}{2}m\dot{r}^2 + \frac{J^2}{2mr^2} - \frac{GMm}{r}$$

Hence $G = G(t)$ so $\frac{dE}{dt} \neq 0$ So total Energy is not conserve

Condition for circular motion

$$\frac{J^2}{mr^3} = \frac{GMm}{r^2} \Rightarrow r \propto \frac{1}{G} \Rightarrow \frac{r_2}{r_1} = \frac{G_1}{G_2} \Rightarrow r_2 = \frac{G_1}{G_2} r_1 \Rightarrow r_2 = \frac{G_1 r_1}{\frac{G_1}{2}} \Rightarrow r_2 = 2r_1$$

- Q24. A particle of mass m moves in One dimension in the potential $V(x) = kx^4, (k > 0)$. at time $t = 0$ the particle starts from rest at $x = A$.

For bounded motion, the time period of its motion is

- proportional to $A^{-1/2}$
- proportional to A^{-1}
- independent of A
- not well-defined (the system is chaotic)

Topic- Classical mechanics

Subtopic- Bohr Summerfield theory

Ans.: (b)

Solution: $J = \oint p dx \Rightarrow J = 4 \int_0^{\left(\frac{E}{k}\right)^{1/4}} \sqrt{2m(E - kx^4)} dx$

$$\frac{p^2}{2m} + kx^4 = E \Rightarrow J \propto 4\sqrt{2mE} \left(\frac{E}{k}\right)^{1/4}$$

$$p = 0, x = A \Rightarrow E = kA^4, \quad J \propto E^{3/4} \Rightarrow T = \frac{dJ}{dE} \propto E^{-1/4} \quad T = kA^{-1}$$

$$T = kA^{-1} \quad T \propto \frac{1}{A}$$

Q25. The infinite square-well potential of a particle in a box of size a is modified as shown in the figure below (assume $\Delta \ll a$)

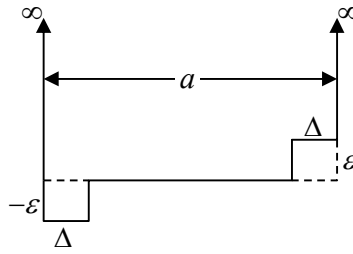

The energy of the ground state, compared to the ground state energy before the perturbation was added

- (a) increases by a term of order ε (b) decreases by a term of order ε
 (c) increases by a term of order ε^2 (d) decreases by a term of order ε^2

Topic- Quantum mechanics
Subtopic- Perturbation

Ans.: (d)

Solution: The perturbation is anti-symmetric about centre at box

So $E_1^1 = 0$

$$E_1^2 = \sum_{m \neq 1} \frac{|\langle \varphi_1 | W | \varphi_m \rangle|^2}{E_1^0 - E_m^0}, E_1^0 > E_m^0 \text{ so } E_1^2 < 0$$

Q26. A quantum particle of mass m in one dimension, confined to a rigid box as shown in the figure, is in its ground state. An infinitesimally thin wall is very slowly raised to infinity at the centre of the box, in such a way that the system remains in its ground state at all times. Assuming that no energy is lost in raising the wall, the work done on the system when the wall is fully raised, eventually separating the original box into two compartments, is

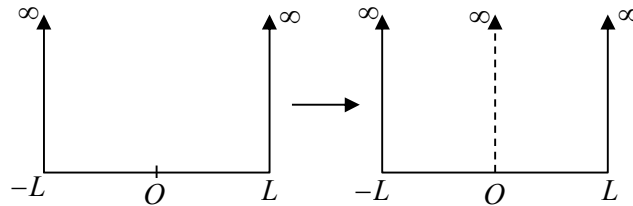

- (a) $\frac{3\pi^2\hbar^2}{8mL^2}$ (b) $\frac{\pi^2\hbar^2}{8mL^2}$ (c) $\frac{\pi^2\hbar^2}{2mL^2}$ (d) 0

Topic- Quantum mechanics
Subtopic- Particle in a box

Ans.: (a)

Solution: Initial particle in ground state

$$E_i = \frac{\pi^2\hbar^2}{2m(2L)^2} = \frac{\pi^2\hbar^2}{8mL^2}$$

here the wall is introduced. Slowly the particle will in ground state at new wall with width

$$L \quad E_f = \frac{\pi^2\hbar^2}{2mL^2}$$

$$\Delta W = E_f - E_i = \frac{\pi^2\hbar^2}{2mL^2} - \frac{\pi^2\hbar^2}{8mL^2} = \frac{3\pi^2\hbar^2}{8mL^2}$$

Q27. The wavefunction of a free particle of mass m , constrained to move in the interval $-L \leq x \leq L$, is $\psi(x) = A(L+x)(L-x)$, where A is the normalization constant. The probability that the particle will be found to have the energy $\frac{\pi^2\hbar^2}{2mL^2}$ is

- (a) 0 (b) $\frac{1}{\sqrt{2}}$ (c) $\frac{1}{2\sqrt{3}}$ (d) $\frac{1}{\pi}$

Topic- Quantum mechanics
Subtopic- Particle in a box

Ans.: (a)

Solution: $E_n = \frac{x^2 \pi^2 \hbar^2}{8mL^2} \Rightarrow E_n = \frac{n^2 \pi^2 \hbar^2}{8mL^2}$

$$E_1 = \frac{\pi^2 \hbar^2}{8mL^2}, |\phi_1\rangle = \sqrt{\frac{2}{2L}} \cos \frac{\pi x}{2L}, -L \leq x \leq L$$

$$E_2 = \frac{4\pi^2 \hbar^2}{8mL^2} = \frac{\pi^2 \hbar^2}{2mL^2} = \sqrt{\frac{2}{2L}} \sin \frac{2\pi x}{2L}, -L \leq x \leq L$$

$$P(E_2) = \frac{|\langle \phi_2 | \psi \rangle|^2}{\langle \psi | \psi \rangle} = \frac{\left| \int_{-L}^L \sqrt{\frac{2}{2L}} \sin \frac{2\pi x}{2L} A(L+x)(L-x) dx \right|^2}{\int_{-L}^L A^2 (L+x)^2 (L-x)^2 dx}$$

$$\int_{-L}^L \sin \frac{2\pi x}{2L} (L+x)(L-x) dx = 0$$

where, $\frac{2\pi x}{2L} (L+x)(L-x)$ is odd

Q28. A particle moving in a central potential is described by a wave function $\psi(r) = zf(r)$ where $r = (x, y, z)$ is the position vector of the particle and $f(r)$ is a function of $r = |r|$. If L is the total angular momentum of the particle, the value of L^2 must be

- (a) $2\hbar^2$ (b) \hbar^2 (c) $4\hbar^2$ (d) $\frac{3}{4}\hbar^2$

Topic- Quantum mechanics
Subtopic- Ladder operator

Ans.: (a)

Solution: $\psi(r) = zf(r) = r \cos \theta f(r)$

$$\cos \theta = P_1(\cos \theta) \Rightarrow l = 1$$

$$\psi(r, \theta, \varphi) = P_1(\cos \theta) r f(r)$$

the measure at L^2 have eigen value

$$l(l+1)\hbar^2 \quad \text{put } l=1 \quad 1(1+1)\hbar^2 = 2\hbar^2$$

Q29. A particle of mass m and energy $E > 0$. in one dimension is scattered by the potential below.

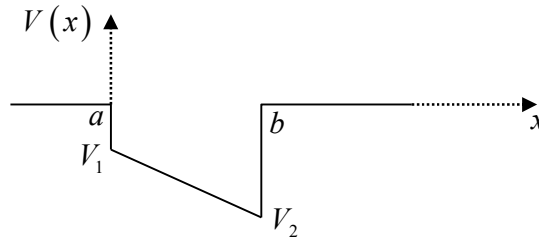

If the particle was moving from $x = -\infty$ to $x = \infty$, which of the following graphs gives the best qualitative representation of the wave function of this particle?

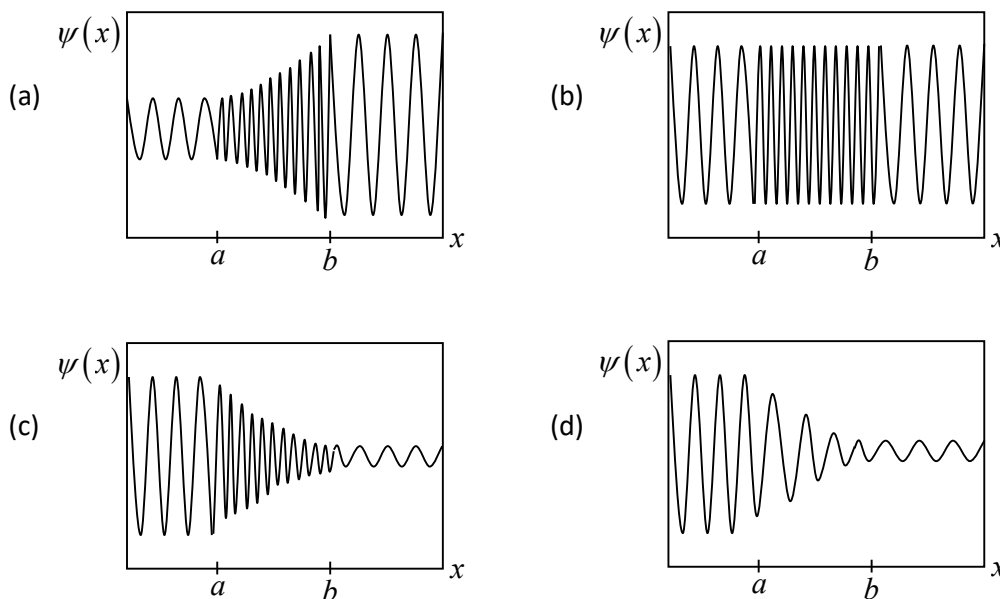

Topic- Quantum mechanics

Subtopic- Wave function

Ans.: (c)

Solution: In classically allowed regions, The local wavelength and local amplitude of the wavelike part of the solution gets shorter as the value of $|E - V(x)|$ increases.

Q30. Consider a planar wire loop as an n -sided regular polygon, in which R is the distance from the centre to a vertex. If a steady current I flows through the wire, the magnitude of the magnetic field at the centre of the Loop is

- (a) $\frac{\mu_0 I}{2R} \sin\left(\frac{2\pi}{n}\right)$ (b) $\frac{\mu_0 n I}{4\pi R} \sin\left(\frac{\pi}{n}\right)$ (c) $\frac{\mu_0 n I}{2\pi R} \tan\left(\frac{2\pi}{n}\right)$ (d) $\frac{\mu_0 n I}{2\pi R} \tan\left(\frac{\pi}{n}\right)$

Topic- Electromagnetic Theory

Subtopic- Magnetic field

Ans. : (d)

Solution: Total angle is 2π

And angle subtended by one side to the centre is $\frac{2\pi}{n}$

For segment (1), $B_1 = \frac{\mu_0 I}{4\pi L} [\sin \theta_2 + \sin \theta_1]$

$$\theta_1 = \theta_2 = \frac{2\pi}{2n} = \frac{\pi}{n} \Rightarrow B_1 = \frac{\mu_0 I}{4\pi L} \left[2 \sin \frac{\pi}{n} \right]$$

$$\cos \theta = \frac{L}{R} \Rightarrow L = R \cos \theta$$

$$\Rightarrow B_1 = \frac{\mu_0 I}{4\pi R \cos \theta} 2 \sin \left(\frac{\pi}{n} \right) = \frac{\mu_0 I}{2\pi R} \tan \left(\frac{\pi}{n} \right)$$

Thus magnetic field due to n -sided polygon is

$$B = nB_1 = \frac{n\mu_0 I}{2\pi R} \tan \left(\frac{\pi}{n} \right)$$

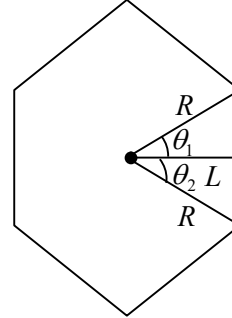

Q31. Two coherent plane electromagnetic waves of wavelength $0.5 \mu\text{m}$ (both have the same amplitude and are linearly polarized along the z -direction) fall on the $y = 0$ plane. Their wave vectors \vec{k}_1 and \vec{k}_2 are as shown in the figure

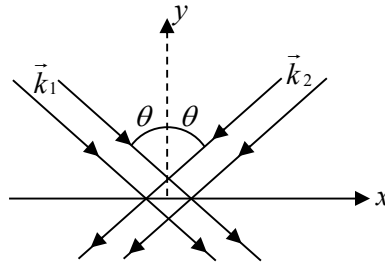

If the angle θ is 30° , the fringe spacing of the interference pattern produced on the plane is

- (a) $1.0 \mu\text{m}$ (b) $0.29 \mu\text{m}$ (c) $0.58 \mu\text{m}$ (d) $0.5 \mu\text{m}$

Topic- Electromagnetic Theory

Subtopic-EM Wave

Ans. : (d)

Solution: $\vec{E}_1 = \hat{z} A e^{i(\omega t - \vec{k}_1 \cdot \vec{r})}$ and $\vec{E}_2 = \hat{z} A e^{i(\omega t - \vec{k}_2 \cdot \vec{r})}$ where $|\vec{k}_1| = |\vec{k}_2|$.

$$\vec{k}_1 = (k_1 \sin \theta) \hat{x} - (k_1 \cos \theta) \hat{y} \text{ and } \vec{k}_2 = -(k_1 \sin \theta) \hat{x} - (k_1 \cos \theta) \hat{y}$$

$$\vec{k}_1 \cdot \vec{r} = (k_1 \sin \theta) x - (k_1 \cos \theta) y \text{ and } \vec{k}_2 \cdot \vec{r} = -(k_1 \sin \theta) x - (k_1 \cos \theta) y$$

$$\vec{E} = \vec{E}_1 + \vec{E}_2 = \hat{z}Ae^{i\omega t} \left[e^{-i(k_1 \sin \theta x - k_1 \cos \theta y)} + e^{-i(-k_1 \sin \theta x - k_1 \cos \theta y)} \right]$$

At $y = 0$,

$$\vec{E} = \hat{z}Ae^{i\omega t} \left[e^{-i(k_1 \sin \theta)x} + e^{i(k_1 \sin \theta)x} \right]$$

$$\vec{E}^* = \hat{z}Ae^{-i\omega t} \left[e^{i(k_1 \sin \theta)x} + e^{-i(k_1 \sin \theta)x} \right]$$

$$I = \vec{E}^* \cdot \vec{E} = A^2 \left[2 + e^{i(2k_1 \sin \theta)x} + e^{-i(2k_1 \sin \theta)x} \right]$$

$$I = A^2 \left[2 + 2 \frac{e^{ik_1 x} + e^{-ik_1 x}}{2} \right] = 2A^2 (1 + \cos k_1 x) \quad \because \theta = 30^\circ$$

For maxima: $\cos k_1 x = +1 \Rightarrow k_1 x_n = 2n\pi \Rightarrow x_n = \frac{2n\pi}{k_1}$

$$x_{n+1} = \frac{2(n+1)\pi}{k_1}$$

$$\beta = x_{n+1} - x_n = \frac{2\pi}{k_1} = \lambda = 0.5 \mu m$$

Q32. Which of the following is **not** a correct boundary condition at an interface between two homogeneous dielectric media? (In the following \hat{n} is a unit vector normal to the interface, σ and \vec{j}_s , are the surface charge and current densities, respectively.)

(a) $\hat{n} \times (\vec{D}_1 - \vec{D}_2) = 0$

(b) $\hat{n} \times (\vec{H}_1 - \vec{H}_2) = \vec{j}_s$

(c) $\hat{n} \cdot (\vec{D}_1 - \vec{D}_2) = \sigma$

(d) $\hat{n} \cdot (\vec{B}_1 - \vec{B}_2) = 0$

Topic- Electromagnetic theory

Subtopic- Boundary conditions

Ans. : (a)

Solution: Boundary condition at an interface between two homogeneous dielectric media:

$$\Rightarrow \hat{n} \cdot (\vec{D}_1 - \vec{D}_2) = \sigma$$

$$\Rightarrow \hat{n} \cdot (\vec{B}_1 - \vec{B}_2) = 0$$

$$\Rightarrow \hat{n} \times (\vec{H}_1 - \vec{H}_2) = \vec{j}_s$$

$$\Rightarrow \hat{n} \times (\vec{E}_2 - \vec{E}_1) = \vec{M}_s$$

Q33. The permittivity tensor of a uniaxial anisotropic medium, in the standard Cartesian basis, is

$$\begin{pmatrix} 4\varepsilon_0 & 0 & 0 \\ 0 & 4\varepsilon_0 & 0 \\ 0 & 0 & 9\varepsilon_0 \end{pmatrix} \text{ where } \varepsilon_0 \text{ is a constant. The wave number of an electromagnetic plane wave}$$

polarized along the x -direction, and propagating along the y -direction in this medium (in terms of the wave number k_0 of the wave in vacuum) is

- (a) $4k_0$ (b) $2k_0$ (c) $9k_0$ (d) $3k_0$

Topic- Electromagnetic theory

Subtopic- EM Wave

Ans.: (b)

Solution: $k_0 = \frac{\omega}{c}, k = \frac{\omega}{c} n = \frac{\omega}{c} \sqrt{\epsilon_r}$

Where $\epsilon_r = 4 \Rightarrow k = \frac{\omega}{c} \sqrt{4} = 2 \frac{\omega}{c} = 2k_0$

Q34. The element of a 3×3 matrix A are the products of its row and column indices $A_{ij} = ij$ (where $i, j = 1, 2, 3$). The eigenvalues of A are

- (a) $(7, 7, 0)$ (b) $(7, 4, 3)$ (c) $(14, 0, 0)$ (d) $\left(\frac{14}{3}, \frac{14}{3}, \frac{14}{3}\right)$

Topic- Mathematical Physics

Subtopic- Matrices

Ans.: (c)

Solution: Since $A_{ij} = ij$ (where $i, j = 1, 2, 3,$)

We obtain the matrix $A = \begin{bmatrix} 1 & 2 & 3 \\ 2 & 4 & 6 \\ 3 & 6 & 9 \end{bmatrix}$

For calculating eigen values $\begin{vmatrix} 1-\lambda & 2 & 3 \\ 2 & 4-\lambda & 6 \\ 3 & 6 & 9-\lambda \end{vmatrix} = 0$

$$(1-\lambda)[(4-\lambda)(9-\lambda)-36]-2[2(9-\lambda)-18]+3(12-3(4-\lambda))=0$$

$$\Rightarrow -\lambda^3 + \lambda^2 \cdot 14 = 0 \Rightarrow \lambda^2(-\lambda + 14) = 0 \Rightarrow \lambda = 0, 0, 14$$

Also, directly for a 3×3 matrix we can write $(0, 0, \text{Trace of } A)$ as Eigen values.

Q35. In the following circuit, each device D may be an insulator with probability p or a conductor with probability $(1-p)$.

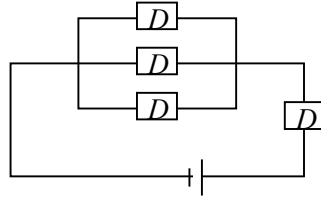

The probability that a non-zero current flows through the circuit is

- (a) $2 - p - p^3$ (b) $(1 - p)^4$
(c) $(1 - p)^2 p^2$ (d) $(1 - p)(1 - p^3)$

Topic- Mathematical Physics

Subtopic- Probability

Ans.: (d)

Solution: For non-zero current,

one of the parallel device should be conducting.

one separate device must be conducting with $P(I) = p$ and $P(C) = 1 - p$.

$$P(1) = 1 - p^3$$

$\because p^3$ is probability being insulator and $(1 - p^3)$ being conductor.

$$P(2) = 1 - p$$

$$\text{Thus } P = P(1)P(2) = (1 - p^3)(1 - p)$$

Q36. The solution of the differential equation $x \frac{dy}{dx} + (1+x)y = e^{-x}$ with the boundary condition

$$y(x=1) = 0, \text{ is}$$

- (a) $\frac{(x-1)}{x} e^{-x}$ (b) $\frac{(x-1)}{x^2} e^{-x}$
(c) $\frac{(1-x)}{x^2} e^{-x}$ (d) $(x-1)^2 e^{-x}$

Topic-Mathematical Physics

Subtopic- Differential equation

Ans.: (a)

Solution: $x \frac{dy}{dx} + (1+x)y = e^{-x} \Rightarrow \frac{dy}{dx} + \frac{(1+x)}{x}y = \frac{e^{-x}}{x}$

Let $p = \frac{1+x}{x}$

$I.F = e^{\int p dx} = e^{\int \left(\frac{1+x}{x}\right) dx} = e^x \cdot e^{\ln x} = x e^x$

$y \cdot x \cdot e^x = \int \frac{e^{-x}}{x} \cdot x e^x dx + C \Rightarrow y \cdot x \cdot e^x = x + C$

$y = 0$ at $x = 1 \Rightarrow C = -1$

$\Rightarrow y \cdot x \cdot e^x = x - 1 \Rightarrow y = \left[\frac{x-1}{x} \right] e^{-x}$

Q37. The value of the definite integral $\int_0^\pi \frac{d\theta}{5+4\cos\theta}$ is

(a) $\frac{4\pi}{3}$

(b) $\frac{2\pi}{3}$

(c) π

(d) $\frac{\pi}{3}$

Topic- Mathematical Physics

Subtopic- Complex analysis

Ans.: (d)

Solution: $I = \frac{1}{2} \int_0^{2\pi} \frac{d\theta}{5+4\cos\theta}$ (even function)

$z = e^{i\theta}$ unit circle

$d\theta = \frac{dz}{iz}$ and $\cos\theta = \frac{1}{2} \left[z + \frac{1}{z} \right] \Rightarrow I = \frac{1}{2} \oint_C \frac{dz/iz}{5+4 \cdot \frac{1}{2} \left[z + \frac{1}{z} \right]} = \frac{1}{4} \oint \frac{dz/i}{z^2 + \frac{5}{2}z + 1}$

Roots for poles: $\frac{-5 \pm 3}{4} = -2, \frac{-1}{2}$

Root -2 is outside unit circle.

Residue at $z = \frac{-1}{2}$ which is simple pole is $= \frac{1}{-\frac{1}{2} + 2} = \frac{2}{3}$

Thus $I = \frac{1}{4i} \times 2\pi i \times \frac{2}{3} = \frac{\pi}{3}$.

- Q38. In a system comprising of approximately 10^{23} distinguishable particles, each particle may occupy any of 20 distinct states. The maximum value of the entropy per particle is nearest to
- (a) $20k_B$ (b) $3k_B$ (c) $10(\ln 2)k_B$ (d) $20(\ln 2)k_B$

Topic- Statistical Mechanics
Subtopic- Number of Microstates

Ans.: (b)

Solution: For N particles; $\omega = 20^N$.

$$S = k_B \ln \omega = k_B \ln 20^N = Nk_B \ln 20 \Rightarrow \frac{S}{N} = k_B \ln 20 \approx 3k_B \quad \because \ln 20 \approx 3$$

- Q39. Consider a classical gas in thermal equilibrium at temperatures T_1 and T_2 where $T_1 < T_2$. Which of the following graphs correctly represents the qualitative behavior of the probability density function of the x -component of the velocity?

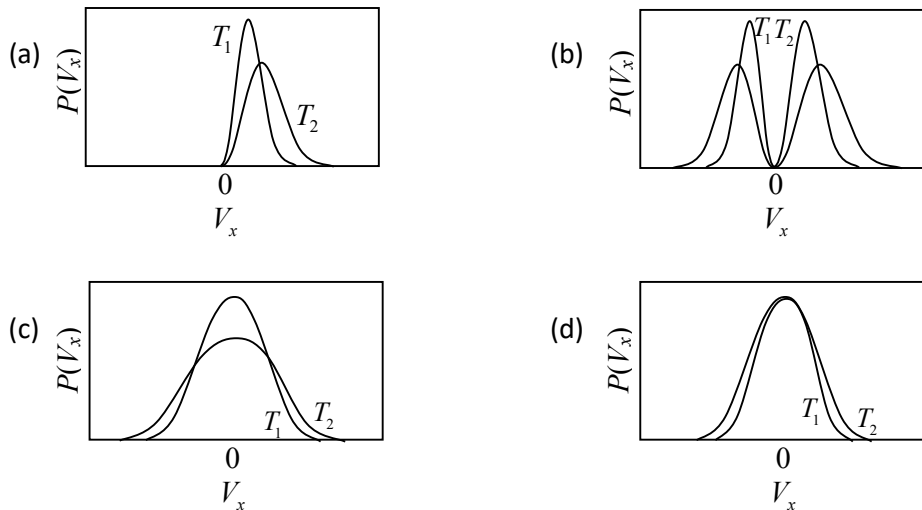

Topic- Statistical Mechanics
Subtopic- Maxwell Boltzmann distribution

Ans. : (c)

Solution: $f(V_x) = \left(\frac{m}{2\pi kT}\right)^{1/2} e^{-\frac{mV_x^2}{2kT}}$ where $-\infty < V_x < \infty$

and $\langle V_x \rangle = 0$, $\langle V_x^2 \rangle = \frac{kT}{m}$, $V_{x,rms} = \sqrt{\frac{kT}{m}}$.

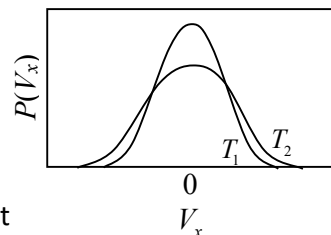

So mean value remains same and r.m.s shift towards right or left hence area under the curve is same. Thus distribution is broad.

Q40. The equation of state of an ideal gas is $pV = RT$. At very low temperatures, the volume expansion coefficient $\frac{1}{V} \frac{\partial V}{\partial T}$ at constant pressure

- (a) diverges as $\frac{1}{T^2}$
- (b) diverges as $\frac{1}{T}$
- (c) vanishes as T
- (d) is independent of the temperature

Topic- Thermodynamics
Subtopic- Ideal gases

Ans. : (b)

Solution: $pV = RT \Rightarrow V = \frac{RT}{p}$

$$\alpha = \frac{1}{V} \cdot \frac{dV}{dT} = \frac{1}{V} \cdot \frac{R}{p} \Rightarrow \alpha = \frac{R}{RT} = \frac{1}{T}. \text{ As } T \rightarrow 0, \alpha \rightarrow \infty.$$

Q41. The Hamiltonian of a classical nonlinear one dimensional oscillator is $H = \frac{1}{2m} p^2 + \lambda x^4$, where $\lambda > 0$ is a constant. The specific heat of a collection of a collection of N independent such oscillators is

- (a) $\frac{3Nk_B}{2}$
- (b) $\frac{3Nk_B}{4}$
- (c) Nk_B
- (d) $\frac{Nk_B}{2}$

Topic- Statistical Mechanics
Subtopic- Canonical Ensemble

Ans. : (b)

Solution: $H = \frac{p^2}{2m} + \lambda x^4, \quad \lambda > 0$

$$\langle H \rangle = \left\langle \frac{p^2}{2m} \right\rangle + \langle V \rangle = \frac{1}{2} k_B T + 2\lambda \frac{\int_0^\infty x^4 e^{-\beta \lambda x^4} dx}{2 \int_0^\infty e^{-\beta \lambda x^4} dx} = \frac{1}{2} k_B T + 2\lambda \frac{\frac{\sqrt{5/4}}{4(\lambda\beta)^{5/4}}}{2 \frac{\sqrt{5/4}}{(\lambda\beta)^{1/4}}}$$

$$\Rightarrow \langle H \rangle = \frac{1}{2} k_B T + \lambda \frac{(\lambda\beta)^{1/4}}{4(\lambda\beta)^{5/4}} = \frac{1}{2} k_B T + \frac{\lambda}{4} \frac{1}{\lambda\beta} = \frac{1}{2} k_B T + \frac{k_B T}{4} = \frac{3}{4} k_B T = \frac{3}{4} k_B T$$

$$\Rightarrow C_V = \frac{3}{4} Nk_B$$

Q42. In an experiment to measure the acceleration due to gravity g using a simple pendulum, the length and time period of the pendulum are measured to three significant figures. The mean value of g and the uncertainty δg of the measurements are then estimated using a calculator from a large number of measurements and found to be 9.82147 m/s^2 and 0.02357 m/s^2 , respectively. Which of the following is the most accurate way of presenting the experimentally determined value of g ?

- (a) $9.82 \pm 0.02 \text{ m/s}^2$ (b) $9.8215 \pm 0.02 \text{ m/s}^2$
(c) $9.82147 \pm 0.02357 \text{ m/s}^2$ (d) $9.82 \pm 0.02357 \text{ m/s}^2$

Topic- Experimental methods

Subtopic- Error analysis

Ans. : (d)

Q43. An ac signal of the type as shown in the figure, is applied across a resistor $R = 1\Omega$.

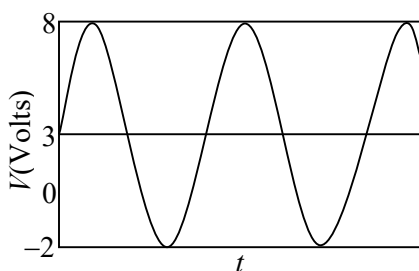

The power dissipated across the resistor is

- (a) 12.5 W (b) 9 W (c) 25 W (d) 21.5 W

Topic- Electronics

Subtopic- Power dissipated

Ans.: (d)

Solution: Peak value $V_m = 5V$, $V_{ms} = \frac{V_m}{\sqrt{2}}$

$$\text{Power dissipated } P_{ac} = \frac{V_{rms}^2}{R} = \frac{V_m^2}{2R} = \frac{25}{2 \times 1} = 12.5 \text{ W}$$

$$P_{dc} = \frac{V^2}{R} = \frac{(3)^2}{1} = 9.0 \text{ W}$$

$$\text{Total Power dissipated } P = P_{ac} + P_{dc} = 12.5 \text{ W} + 9.0 \text{ W} = 21.5 \text{ W}$$

Q44. An *npn*-transistor is connected in a voltage divider configuration as shown in the figure below.

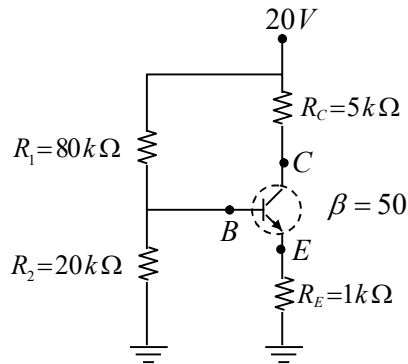

If the resistor R_2 is disconnected, the voltages V_B at the base and V_C at the collector change as follows.

- | | |
|--|--|
| (a) both V_B and V_C increase | (b) both V_B and V_C decrease |
| (c) V_B decreases, but V_C increases | (d) V_B increases, but V_C decreases |

Topic- Electronics
Subtopic- Transistor

Ans.: (d)

Solution: $V_B = \frac{V_{CC}R_2}{R_1 + R_2} = \frac{V_{CC}}{R_1/R_2 + 1}$ as $R_2 \uparrow, V_B \uparrow$

$\therefore V_E = V_B - V_{BE}$ and $I_E = \frac{V_E}{R_E} \approx I_C$.

As $V_B \uparrow, V_E \uparrow$ thus $I_E \approx I_C \uparrow$

$\therefore V_{CC} = V_{CC} - I_C R_C$, as $I_C \uparrow, V_C \downarrow$

PART - C

Q45. Let Y denote the output in the following logical Circuit.

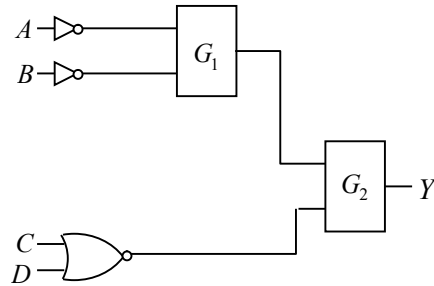

If $Y = AB + \overline{CD}$, the gates G_1 and G_2 must, respectively, be

- (a) OR and NAND (b) NOR and OR (c) AND and NAND (d) NAND and OR

Topic- Electronics

Subtopic- Logic gates

Ans.: (b)

Solution: 1. $Y = \overline{(\overline{A+B})} + \overline{(\overline{C+D})} = \overline{(\overline{A+B})} + \overline{(\overline{C+D})} = AB + CD$

2. $Y = \overline{(\overline{A+B})} + (\overline{C+D}) = AB + \overline{CD}$

3. $Y = \overline{(\overline{A+B})} + \overline{(\overline{C+D})} = \overline{\overline{A+B}} + \overline{(\overline{C+D})} = (A+B) + (C+D)$

4. $Y = \overline{\overline{A+B}} + (\overline{C+D}) = A+B + \overline{CD}$

Q46. A solid spherical Cork of radius R and specific gravity 0.5 floats on water. The cork is pushed down so that its centre of mass is at a distance h (where $0 < h < R$) below the surface of water, and Then released. The volume of the part of the cork above water level is $\pi R^3 \left(\frac{2}{3} - \cos \theta_0 + \frac{1}{3} \cos^3 \theta_0 \right)$ where θ_0 is the angle as shown in the figure.

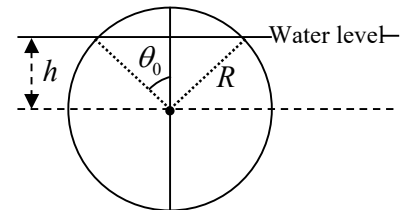

At the moment of release, the dependence of the upward force on the cork on h is

- (a) $\frac{h}{R} - \frac{1}{3} \left(\frac{h}{R} \right)^3$ (b) $\frac{h}{R} + \frac{1}{3} \left(\frac{h}{R} \right)^3$ (c) $\frac{h}{R} - \frac{2}{3} \left(\frac{h}{R} \right)^3$ (d) $\frac{h}{R} + \frac{2}{3} \left(\frac{h}{R} \right)^3$

Topic- Classical Mechanics

Subtopic- Buoyant force

Ans.: (a)

Solution: Volume of sphere = $\frac{4\pi}{3}R^3$

Weight of sphere = $\frac{4\pi}{3}R^3g \times 0.5 \Rightarrow F_w = \frac{2\pi}{3}R^3g$ in down ward direction

Volume of liquid displaced by cork

$$\frac{4\pi R^3}{3} - \pi R^3 \left[\frac{2}{3} - \cos \theta_0 + \frac{1}{3} \cos^3 \theta_0 \right] = \frac{2\pi R^3}{3} + \pi R^3 \cos \theta_0 - \frac{\pi R^3}{3} \cos^3 \theta_0 \quad \cos \theta_0 = \frac{h}{R}$$

$$V_1 = \frac{2\pi R^3}{3} + \left(\frac{h}{R} - \frac{1}{3} \left(\frac{h}{R} \right)^3 \right) \pi R^3$$

weight at displaced liquid $V_1 d g$ where $d = 1$

$$F_B = \frac{2\pi R^3}{3} g + \left[\frac{h}{R} - \frac{1}{3} \left(\frac{h}{R} \right)^3 \right] g \pi R^3$$

$$\Delta F = F_B - F_w = \left[\frac{h}{R} - \frac{1}{3} \left(\frac{h}{R} \right)^3 \right] \pi R^3$$

$$\Delta F \propto \frac{h}{R} - \frac{1}{3} \left(\frac{h}{R} \right)^3. \text{ Option (a) is correct}$$

Q47. Two particles of masses m_1 and m_2 are connected by a mass less thread of length l as shown in figure.

The particle of mass m_1 on the plane undergoes a circular motion with radius r_0 and angular momentum L . When a small radial displacement ϵ (where $\epsilon \ll r_0$) is applied, its radial coordinate is

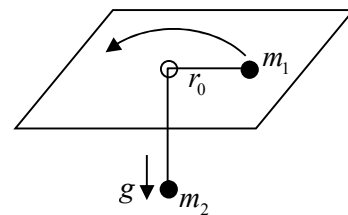

found to oscillate about r_0 . The frequency of the oscillations is

(a) $\sqrt{\frac{7m_2g}{\left(m_1 + \frac{m_2}{2}\right)r_0}}$

(b) $\sqrt{\frac{7m_2g}{(m_1 + m_2)r_0}}$

(c) $\sqrt{\frac{3m_2g}{\left(m_1 + \frac{m_2}{2}\right)r_0}}$

(d) $\sqrt{\frac{3m_2g}{(m_1 + m_2)r_0}}$

Topic-Classical Mechanics

Subtopic- Lagrangian

Ans.: (d)

Solution: $L = \frac{1}{2}(m_1 + m_2)\dot{r}^2 + \frac{1}{2}m_1r^2\dot{\theta}^2 - m_2g(l - r)$

Lagrangian equation at motion

$$\frac{d}{dt}\left(\frac{\partial L}{\partial \dot{r}}\right) - \frac{\partial L}{\partial r} = 0$$

$$(m_1 + m_2)\ddot{r} - m_1r\dot{\theta}^2 + m_2g = 0$$

Hence angular momentum is conserve

$$m_1r^2\dot{\theta} = m_1r_0^2\dot{\theta}_0 \Rightarrow \dot{\theta} = \frac{r_0^2\dot{\theta}_0}{r^2} \quad (i)$$

$$\text{For circular motion } mr_0\dot{\theta}_0^2 = m_2g \quad (ii)$$

$$\text{so } r\dot{\theta}^2 = \frac{m_2}{m_1}\left(\frac{r_0}{r}\right)^3 g$$

$$(m_1 + m_2)\ddot{r} - m_2\left(\frac{r_0}{r}\right)^3 g + m_2g = 0$$

$$\text{Put } r = r_0 + \epsilon \quad \ddot{r} = \ddot{\epsilon}$$

$$(m_1 + m_2)\ddot{\epsilon} - m_2\left(\frac{r_0}{r_0 + \epsilon}\right)^3 g + m_2g$$

$$(m_1 + m_2)\ddot{\epsilon} - m_2r_0^3(r_0 + \epsilon)^{-3} g + m_2g$$

$$(m_1 + m_2)\ddot{\epsilon} - m_2r_0^3gr_0^{-3}\left(1 + \frac{\epsilon}{r_0}\right)^{-3} + m_2g = 0$$

$$(m_1 + m_2)\ddot{\epsilon} + \frac{m_2 3\epsilon}{r_0} = 0 \Rightarrow \omega = \sqrt{\frac{3m_2g}{(m_1 + m_2)r_0}}$$

Option (d) is correct

Q48. The time evolution of a coordinate x of a particle is described by the equation

$$\frac{d^2x}{dt^4} + 2\Omega^2 \frac{d^2x}{dt^2} + (\Omega^4 - A^4)x = 0$$

For $\Omega > A$, the particle will

(a) eventually come to rest at the origin

(b) eventually drift to infinity ($|x| \rightarrow \infty$)

(c) oscillate about the origin

(d) eventually come to rest at $\frac{\Omega}{A}$ or $-\frac{\Omega}{A}$

Topic- Mathematical Physics

Subtopic-DE and Forced oscillations

Ans.: (c)

Solution: Let $x = e^{kt}$ (degree is one)

$$k^4 + 2\Omega^2 k^2 + (\Omega^4 - A^4) = 0$$

$$\text{Put } k^2 = u \Rightarrow u^2 + 2\Omega^2 u + (\Omega^4 - A^4) = 0$$

$$u = -\Omega^2 \pm A^2$$

$$u = -\Omega^2 - A^2, -\Omega^2 + A^2$$

$$u = -(\Omega^2 + A^2), -(\Omega^2 - A^2)$$

$$k^2 = -(\Omega^2 + A^2), k^2 = -(\Omega^2 - A^2)$$

$$k = \pm i\sqrt{\Omega^2 + A^2}, k = \pm i\sqrt{\Omega^2 - A^2}; \quad \Omega > A$$

So, Oscillatory about the origin.

Q49. The Hamiltonian of A quantum particle of mass m is $H = \frac{p^2}{2m} + \alpha|x|^r$, where α and r are positive constants. The energy E_n of the n^{th} level for large n , depends on n as

- (a) n^{2r} (b) n^{r+2} (c) $n^{1/(r+2)}$ (d) $n^{2r/(r+2)}$

Topic- Classical mechanics

Subtopic- Bohr Summerfield theory

Ans.: (d)

Solution: According to Bohr Summerfield theorem,

$$E = \frac{P_x^2}{2m} + \alpha|x|^r \Rightarrow P_x = 0 \quad x = \pm \left(\frac{E}{\alpha}\right)^{1/r}$$

$$\oint P_x dx = nh$$

$$\oint \sqrt{2m(E - \alpha|x|^r)} dx = nh$$

$$4 \int_0^{\left(\frac{E}{\alpha}\right)^{1/r}} \sqrt{2m(E - \alpha x^r)} dx = nh$$

$$4 \times \sqrt{2mE} \times \left(\frac{E}{\alpha}\right)^{1/r} \int_0^1 \sqrt{1-t^r} dt = nh$$

$$E^{1/2} E^{1/r} \propto n \Rightarrow E^{\frac{r+2}{2r}} \propto n \Rightarrow E \propto n^{\frac{2r}{r+2}}$$

Q50. In the partial wave expansion, the differential scattering cross-section is given by

$$\frac{d\sigma}{d(\cos\theta)} = \left| \sum_l (2l+1) e^{i\delta_l} \sin \delta_l P_l(\cos\theta) \right|^2$$

where θ is the scattering angle. For a certain neutron-nucleus scattering, it is found that the two lowest phase shifts δ_0 and δ_1 corresponding to s -wave and p -wave, respectively, satisfy

$\delta_1 \approx \frac{\delta_0}{2}$. Assuming that the other phase shifts are negligibly small, the differential cross-section

reaches its minimum for $\cos\theta$ equal to

- (a) 0 (b) ± 1 (c) $-\frac{2}{3} \cos^2 \delta_1$ (d) $\frac{1}{3} \cos^2 \delta_1$

Topic- Quantum mechanics

Subtopic- Scattering

Ans.: (c)

Solution: $D(\theta) = \sum_l (2l+1) e^{i\delta_l} \sin \delta_l P_l(\cos\theta)$

$l = 0, 1$ Let $l_1 = 0, 1$ $l_2 = 0, 1$

$$D(\theta) = \left(\sum_{l_1} (2l_1+1) e^{i\delta_{l_1}} \sin \delta_{l_1} P_{l_1}(\cos\theta) \right) \left(\sum_{l_2} (2l_2+1) e^{-i\delta_{l_2}} \sin \delta_{l_2} P_{l_2}(\cos\theta) \right)$$

Put $l_1 = 0, 1$ Put $l_2 = 0, 1$

$$D(\theta) = [e^{i\delta_0} \sin \delta_0 P_0(\cos\theta)] [e^{-i\delta_0} \sin \delta_0 P_0(\cos\theta)] + [3e^{i\delta_1} \sin \delta_1 P_1(\cos\theta)] [3e^{-i\delta_1} \sin \delta_1 P_1(\cos\theta)] + [e^{i\delta_0} \sin \delta_0 P_0(\cos\theta)] [3e^{-i\delta_1} \sin \delta_1 P_1(\cos\theta)] + [3e^{i\delta_1} \sin \delta_1 P_1(\cos\theta)] [e^{-i\delta_0} \sin \delta_0 P_0(\cos\theta)]$$

$$D(\theta) = \sin^2 \delta_0 + 9 \sin^2 \frac{\delta_0}{2} \cos^2 \theta + \frac{3}{2} \sin^2 \delta_0 \cos \theta [e^{i\delta_0} e^{-i\delta_1} + e^{i\delta_1} e^{-i\delta_0}]$$

$$D(\theta) = \sin^2 \delta_0 + 9 \sin^2 \delta_1 \cos^2 \theta + 3 \sin \delta_0 \sin \delta_1 P_1(\cos\theta) [e^{i\delta_0} e^{-i\delta_1} + e^{i\delta_1} e^{-i\delta_0}]$$

$$\left(\frac{dD}{d\theta} \right) = 0 = 18 \sin^2 \frac{\delta_0}{2} (-\sin \theta \cos \theta) + \frac{3}{2} \sin^2 \delta_0 (-\sin \theta) = 0$$

$\sin \theta = 0, \cos \theta = \pm 1$

$$\cos \theta \sin^2 \frac{\delta_0}{2} + \frac{3}{2} \sin^2 \delta_0 = 0 \quad \cos \theta = -\frac{2}{3} \cos^2 \frac{\delta_0}{2} = -\frac{2}{3} \cos^2 \delta_1$$

- Q51. A charged, spin-less particle of mass m is subjected to an attractive potential $V(x, y, z) = \frac{1}{2}k(x^2 + y^2 + z^2)$, where k is a positive constant. Now a perturbation in the form of a weak magnetic field $B = B_0 \hat{k}$ (where B_0 is a constant is switched on. Into how many distinct levels will the second excited state of the unperturbed Hamiltonian split?
- (a) 5 (b) 4 (c) 2 (d) 1

Topic- Relativistic Quantum mechanics

Subtopic- Energy level

Ans.: (a)

Solution: $B = B_0 \hat{k}$

We can choose vector potential

$$A_\rho = 0, \quad A_z = 0 \quad A_\phi = \frac{1}{2} B_0 \rho$$

$$H = \frac{1}{2m} \left[\vec{P} - \frac{q\vec{A}}{c} \right]^2 + V = \frac{1}{2} \frac{P_\rho^2}{m} - \frac{q}{mc} \vec{P} \cdot \vec{A} + \frac{q^2}{2mc^2} A^2 + \frac{1}{2} k P^2 + \frac{1}{2} k z^2$$

$$\vec{A} \cdot \vec{A} = 0 \quad \vec{P} \cdot \vec{A} = \vec{A} \cdot \vec{P} = \frac{P_\rho^2 e}{2m} + \frac{1}{2} m \omega_0^2 \rho^2 + \left(\frac{P_z^2}{2m} + \frac{1}{2} k z^2 \right) - \frac{Q B_0}{2mc} \vec{L}_z$$

where $\vec{L}_z = \hat{P}_z \rho$ $\omega_0 = \frac{QB}{2mc}$

we write our Hamiltonian in cylindrical co-ordinate

$$E_{n_x, n_y, n_z, m} = E_{(n_x, n_y), n_z, m}$$

$$n_\rho = 0, 1, 2, 3, \dots$$

$$n_z = 0, 1, 2, 3, \dots$$

$$E = (n_x + n_y + 1) \hbar \omega_1 + \left(n_z + \frac{1}{2} \right) \hbar \omega_2 + m \hbar \omega_0$$

$E_{(2,0,0)} + \omega_0 \hbar$	$E_{0,2,0} + \omega_0 \hbar$	→ (i) Same energy level
--------------------------------	------------------------------	-------------------------

$E_{(2,0,0)} - \omega_0 \hbar$	$E_{0,2,0} - \omega_0 \hbar$	→ (ii) Energy level
--------------------------------	------------------------------	---------------------

$E_{1,1,0} + \omega_0 \hbar$	→ (iii) Energy level
------------------------------	----------------------

$E_{110} - \omega_0 \hbar$	→ (iv) Energy level
----------------------------	---------------------

so it splits into (iv) level

(other solutions are also welcome)

Q52. The elastic scattering of a charged particle of mass m off an atom can be approximated by the

potential $V(r) = \frac{\alpha}{r} e^{-r/R}$ where α and R

are positive constants. If the wave number of the incoming particle is k and the scattering angle is 2θ , the differential cross-section in the Born approximation is

(a) $\frac{m^2 \alpha^2 R^4}{4\hbar^4 (1 + k^3 R^2 \sin^2 \theta)}$

(b) $\frac{m^2 \alpha^2 R^4}{\hbar^4 (2k^2 R^2 \sin^2 \theta)^2}$

(c) $\frac{2m^2 \alpha^2 R^4}{\hbar^4 (2k^2 R^2 \sin^2 \theta)}$

(d) $\frac{4m^2 \alpha^2 R^4}{\hbar^4 (1 + 4k^2 R^2 \sin^2 \theta)^2}$

Topic- Quantum mechanics

Subtopic- Scattering

Ans.: (d)

Solution: $V(r) = \frac{\alpha}{r} e^{-r/R}$

$$f(\theta) = \frac{-2m}{\hbar^2 q} \int_0^\infty r V(r) \sin qr \, dr$$

$$q = 2k \sin \theta \quad \text{where } 2\theta \text{ is scattering angle } D(\theta) = |f(\theta)|^2$$

$$f(\theta) = \frac{-2m}{\hbar^2 q} \int_0^\infty r \frac{\alpha}{r} e^{-r/R} \sin qr \, dr$$

$$\text{put } \sin qr = \frac{e^{iqr} - e^{-iqr}}{2i}$$

$$f(\theta) = \frac{-2m\alpha}{\hbar^2 \left[\frac{1}{R^2} + q^2 \right]}$$

$$D(\theta) = \frac{4m^2 \alpha^2}{\hbar^2 \left[\frac{1}{R^2} + (2k \sin \theta)^2 \right]^2} = \frac{4m^2 \alpha^2 R^2}{\hbar^4 [1 + 4R^2 k^2 \sin^2 \theta]^2}$$

Q53. The wave number k and the angular frequency ω of a wave are related by the dispersion relation $\omega^2 = \alpha k + \beta k^3$ where α and β are positive constants. The wave number for which the phase velocity equals the group velocity, is

(a) $3\sqrt{\frac{\alpha}{\beta}}$

(b) $\sqrt{\frac{\alpha}{\beta}}$

(c) $\frac{1}{2}\sqrt{\frac{\alpha}{\beta}}$

(d) $\frac{1}{3}\sqrt{\frac{\alpha}{\beta}}$

Topic- Solid state physics

Subtopic- Phase and group velocity

Ans.: (b)

Solution: $\omega^2 = \alpha k + \beta k^3 \Rightarrow \omega = \sqrt{\alpha k + \beta k^3}$

$$\frac{d\omega}{dk} = \frac{\alpha + 3\beta k^2}{2\sqrt{\alpha k + \beta k^3}} = \frac{\alpha + 3\beta k^2}{2\omega} = v_g \quad (1)$$

also $\frac{\omega}{k} = \frac{\sqrt{\alpha k + \beta k^3}}{k} = v_p \quad (2)$

$$v_g = v_p \Rightarrow \frac{\omega}{k} = \frac{\alpha + 3\beta k^2}{2\omega} \Rightarrow 2\alpha + 2\beta k^2 = \alpha + 3\beta k^2 \Rightarrow \alpha = \beta k^2 \Rightarrow k = \sqrt{\frac{\alpha}{\beta}}$$

Q54. A inertial observer A at rest measures the electric and magnetic field $E = (\alpha, 0, 0)$ and $B = (\alpha, 0, 2\alpha)$ in a region, where α is a constant. Another inertial observer B , moving with a constant velocity with respect to A , measures the fields as $E' = (E'_x, \alpha, 0)$ and $B' = (\alpha, B'_y, \alpha)$. Then in units $c = 1$, E'_x and B'_y are given, respectively, by

- (a) -2α and α (b) 2α and $-\alpha$ (c) α and -2α (d) $-\alpha$ and 2α

Topic- Classical Mechanics

Subtopic- STR

Ans.: (c)

Solution: From S

$E \cdot B$ is invariant and $E^2 - B^2$ is invariant

$$E_x'^2 - B_y'^2 = -3\alpha^2$$

$$E_x' + B_y' = \alpha \text{ (Solving these two equation)}$$

$$E_x' = -\alpha, \quad B_y' = 2\alpha$$

Option 4 is correct.

Q55. A point charge is moving with a uniform velocity βc along the positive x -direction, parallel to and very close to a corrugated metal sheet (see the figure).

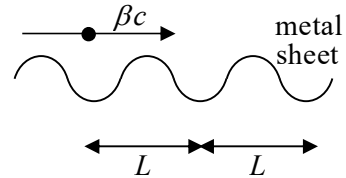

The wavelength of the electromagnetic radiation received by an observer along the direction of motion is

- (a) $\frac{1}{\beta} \sqrt{1 - \beta^2}$ (b) $L \sqrt{1 - \beta^2}$ (c) $L \beta \sqrt{1 - \beta^2}$ (d) L

Topic- Classical Mechanics

Subtopic- Doppler effect

Ans.: (a)

Solution: Assume the wavelength at radiation if choose is rest with respect to observe = $\lambda_0 = L$

From Doppler effect if relation move towards observe

$$\lambda = L \sqrt{\frac{1-\beta}{1+\beta}} \sqrt{\frac{1+\beta}{1+\beta}}$$

$$\lambda = L \sqrt{\frac{(1-\beta)(1+\beta)}{(1+\beta)(1+\beta)}}$$

$$\lambda = \frac{L}{1+\beta} \sqrt{1-\beta^2} \quad \lambda \approx \frac{1}{\beta} \sqrt{1-\beta^2} \quad 1+\beta \approx \beta$$

Q56. If the Newton-Raphson method is used to find the positive root of the equation $x = 2 \sin x$, the iteration equation is

(a) $x_{n+1} = \frac{2x_n - 2(\sin x_n + x_n \cos x_n)}{1 - 2 \cos x_n}$

(b) $x_{n+1} = \frac{2(\sin x_n - x_n \cos x_n)}{1 - 2 \cos x_n}$

(c) $x_{n+1} = \frac{x_n^2 - 1 + 2(\cos x_n - x_n \sin x_n)}{x_n - 2 \sin x_n}$

(d) $x_{n+1} = \frac{x_n^2 - 1 - 2(\cos x_n + \sin x_n)}{x_n - 2 \sin x_n}$

Topic- Mathematical Physics

Subtopic- Newton Raphson method

Ans.: (b)

Solution: $f(x) = x - 2 \sin x \Rightarrow f'(x) = 1 - 2 \cos x$

$$x_{n+1} = x_n - \frac{f(x)}{f'(x)}$$

$$x_{n+1} = x_n - \frac{(x_n - 2 \sin x_n)}{1 - 2 \cos x_n} = \frac{x_n - 2x_n \cos x_n - x_n + 2 \sin x_n}{1 - 2 \cos x_n}$$

$$x_{n+1} = \frac{2[\sin x_n - x_n \cos x_n]}{1 - 2 \cos x_n}$$

Q57. The equation of motion of a forced simple harmonic oscillator is $\ddot{x} + \omega^2 x = A \cos \Omega t$, where A is a constant. At resonance $\Omega = \omega$ the amplitude of oscillations at large times

(a) saturates to a finite value

(b) increases with time as \sqrt{t}

(c) increases linearly with time

(d) increases exponentially with time

Topic- Mathematical Physics

Subtopic- Forced oscillations

Ans. : (c)

Solution: $\ddot{x} + \omega^2 x = A \cos \Omega t$

$$x = \frac{A \cos \Omega t}{-\Omega^2 + \omega^2} + A \cos \omega t + B \sin \omega t$$

Calculate limit $\Omega \rightarrow \omega$ of x Using L hospitals rule.

$$\Rightarrow x \propto t$$

Q58. The operator A has a matrix representation $\begin{pmatrix} 2 & 1 \\ 1 & 2 \end{pmatrix}$ in the basis spanned by $\begin{pmatrix} 1 \\ 0 \end{pmatrix}$ and $\begin{pmatrix} 0 \\ 1 \end{pmatrix}$. In

another basis spanned by $\frac{1}{\sqrt{2}}\begin{pmatrix} 1 \\ 1 \end{pmatrix}$ and $\frac{1}{\sqrt{2}}\begin{pmatrix} 1 \\ -1 \end{pmatrix}$, the matrix representation of A is

- (a) $\begin{pmatrix} 2 & 0 \\ 0 & 2 \end{pmatrix}$ (b) $\begin{pmatrix} 3 & 0 \\ 0 & 1 \end{pmatrix}$ (c) $\begin{pmatrix} 3 & 1 \\ 0 & 1 \end{pmatrix}$ (d) $\begin{pmatrix} 3 & 0 \\ 1 & 1 \end{pmatrix}$

Topic- Quantum mechanics

Subtopic- Postulates

Ans.: (b)

Solution: The given vector $\frac{1}{\sqrt{2}}\begin{pmatrix} 1 \\ 1 \end{pmatrix}$ and $\frac{1}{\sqrt{2}}\begin{pmatrix} 1 \\ -1 \end{pmatrix}$ are eigen vectors of operator A .

Hence in this basis matrix A is represented by diagonal matrix D consisting of eigenvalues of matrix A on the main diagonal. Therefore,

$$D = \begin{bmatrix} 3 & 0 \\ 0 & 1 \end{bmatrix}$$

Q59. The operator $x \frac{d}{dx} \delta(x)$, where $\delta(x)$ is the Dirac delta function, acts on the space of real-valued square-integrable functions on the real line. This operator is equivalent to

- (a) $-\delta(x)$ (b) $\delta(x)$ (c) x (d) 0

Topic- Mathematical Physics

Subtopic- Dirac delta function

Ans.: (a)

Solution: We know, $x\delta'(x) = -\delta(x)$ (can be proved using integral by parts)

$$\delta'(x) = -\frac{\delta(x)}{x}$$

so, $x\delta'(x) = -\delta(x)$

Q60. At each time step, a random walker in one dimension either remains at the same point with probability $\frac{1}{4}$, or moves by a distance Δ to the right or left with probabilities $\frac{3}{8}$ each. After N time steps, its root mean squared displacement is

- (a) $\Delta\sqrt{N}$ (b) $\Delta\sqrt{\frac{9N}{16}}$ (c) $\Delta\sqrt{\frac{3N}{4}}$ (d) $\Delta\sqrt{\frac{3N}{8}}$

Topic- Statistical Mechanics
Subtopic- Random walk

Ans. : (c)

Solution: For this problem it is evident from problem and given options, $x_{rms} = k\sqrt{N}$

If $N = 1$ (Special case) (Let)

Outcomes $1, 0, -1$ (Times Δ) with probability $\frac{3}{8}, \frac{1}{4}, \frac{3}{8}$

$$\langle x^2 \rangle = \sum P_i X_i^2 = \frac{3}{8} \cdot 1 + \frac{1}{4} \cdot 0 + \frac{3}{8} \cdot 1 = \frac{3}{4} \Rightarrow x_{rms} = \sqrt{\frac{3}{4}} \cdot 1$$

So, option $\Delta\sqrt{\frac{3N}{4}}$ is correct.

Q61. The Hamiltonian of three Ising spins S_1, S_2 and S_3 , each taking values ± 1 , is $H = -J(S_1S_2 + S_2S_3) - hS_1$, where J and h are positive constants. The mean value of S_3 in equilibrium at a temperature $T = 1/(k_B\beta)$, is

- (a) $\tanh^3(\beta J)$ (b) $\tan(\beta h)\tanh^2(\beta J)$
(c) $\sinh(\beta h)\sinh^2(\beta J)$ (d) 0

Topic- Statistical Mechanics
Subtopic- Ising model

Ans. : (b)

Solution:

S_1	S_2	S_3	H
1	1	1	$-2J - h$
1	1	-1	$-h$
1	-1	1	$2J - h$
1	-1	-1	$-h$
-1	1	1	$+h$
-1	1	-1	$2J + h$
-1	-1	1	$+h$
-1	-1	-1	$-2J + h$

$$Z = e^{-\beta(-2J-h)} + 2e^{\beta h} + e^{-\beta(2J-h)} + 2e^{-\beta h} + e^{-\beta(2J+h)} + e^{-\beta(-2J+h)}$$

$$Z = e^{\beta 2J} e^{\beta h} + 2e^{\beta h} + e^{-\beta 2J} \cdot e^{\beta h} + 2e^{-\beta h} + e^{-\beta 2J} \cdot e^{-\beta h} + e^{\beta 2J} \cdot e^{-\beta h}$$

$$Z = 4 \cosh \beta h [\cos \beta 2J + 1]$$

$$\langle X_i \rangle = \sum_i P_i X_i$$

$$\langle S_3 \rangle = P(1) \cdot 1 + P(-1) \cdot (-1)$$

$$\langle S_3 \rangle = \frac{e^{-\beta(-2J-h)} + e^{-\beta(2J-h)} + e^{-\beta h} + e^{-\beta h}}{Z} \cdot 1 + \frac{e^{\beta h} + e^{\beta h} + e^{-\beta(2J+h)} + e^{-\beta(-2J+h)}}{Z}$$

$$\langle S_3 \rangle = \frac{4 \sinh h \beta h [\cosh \beta 2J - 1]}{4 \cosh \beta h [\cosh \beta 2J + 1]} = \tanh \beta h \cdot \tanh^2 \beta J$$

$$\therefore \frac{e^{2x} + e^{-2x} - 2}{e^{2x} + e^{-2x} + 2} = \frac{(e^x - e^{-x})}{(e^x + e^{-x})^2}$$

Q62. The free energy of a magnetic system, as a function of its magnetization m , is $F = \frac{1}{2} am^2 - \frac{1}{4} bm^4 + \frac{1}{6} m^6$. where a and b are positive constants.

At a fixed value of a , the critical value of b , above which the minimum of F will be at a non-zero value of magnetization, is

(a) $\sqrt{\frac{10a}{3}}$

(b) $\sqrt{\frac{16a}{3}}$

(c) $\frac{10}{3}\sqrt{a}$

(d) $\frac{16}{3}\sqrt{a}$

Topic- Statistical Mechanics

Subtopic- GL Theory for Second order Phase transition

Ans. : (b)

Solution: $f = \frac{1}{2} am^2 - \frac{1}{4} bm^4 + \frac{1}{6} m^6$

Let $m^2 = t$

$$f = \frac{1}{2} at - \frac{1}{4} bt^2 + \frac{1}{6} t^3 \Rightarrow \frac{df}{dt} = \frac{1}{2} a - \frac{1}{2} bt + \frac{1}{2} t^2 = 0 \Rightarrow t^2 - bt + a = 0$$

$$\Rightarrow t = \frac{+b \pm \sqrt{b^2 - 4a}}{2}$$

So values of t are $\alpha = \frac{b + \sqrt{b^2 - 4a}}{2}$ and $\beta = \frac{b - \sqrt{b^2 - 4a}}{2}$.

Now $\frac{d^2 f}{dt^2} = + \frac{1}{2} [-b + 2t]$

Thus $\frac{d^2f}{dt^2} = +ve$ for α and $\frac{d^2f}{dt^2} = -ve$ for β

Minima for $\alpha = \frac{b + \sqrt{b^2 - 4a}}{2}$.

$$f_{\min} = \frac{1}{2}at - \frac{1}{4}bt^2 + \frac{1}{6}t^3 \quad f_{\min} = \frac{1}{2}a \left[\frac{b + \sqrt{b^2 - 4a}}{2} \right] - \frac{1}{4}b \left[\frac{b + \sqrt{b^2 - 4a}}{2} \right]^2 + \frac{1}{6} \left[\frac{b + \sqrt{b^2 - 4a}}{2} \right]^3 < 0$$

The value of b above which F is minimum

$$b = \frac{4\sqrt{a}}{\sqrt{3}} = \sqrt{\frac{16}{3}}a \quad a > 0$$

- Q63. For optimal performance of an op-amp based current-to-voltage converter circuit, the input and output impedance should be
- Low input impedance and high output impedance
 - low input impedance and low output impedance
 - high input impedance and high output impedance
 - high input impedance and low output impedance

Topic- Electronics

Subtopic- Operational Amplifier

Ans.: (b)

Q64. The forward diode current is given by

$I = K T^\alpha e^{-E_g/k_B T} (\exp(eV/k_B T) - 1)$, where E_g is the band gap of the semiconductor, V is the voltage drop across the diode, T is the temperature of the diode operating near room temperature and, α and K are constants. A diode is used as a thermal sensor in the circuit shown below.

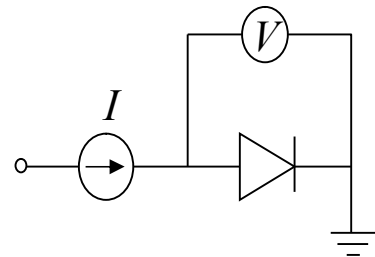

If V is measured using an ideal voltmeter to estimate T , the variation of the voltage V as a function of T is best approximated by (in the following a and b are constants)

- (a) $aT^2 + b$ (b) $aT + b$ (c) $aT^3 + b$ (d) $aT + bT^2$

Topic- Electronics

Subtopic- Diode current

Ans.: (b)

Solution: $I = kT^\alpha e^{-E_g/k_B T} \left(1 + \frac{eV}{k_B T} - 1 \right)$

$$\Rightarrow \frac{eV}{k_B T} = I \frac{T^{-\alpha} e^{E_g/k_B T}}{k} \Rightarrow \frac{eV}{k_B T} = I \frac{T^{-\alpha}}{k} \left(1 + \frac{E_g}{k_B T} \right)$$

$$\Rightarrow V = aT^{-\alpha+1} + bT^{-\alpha}, \text{ where } \alpha = 0, \Rightarrow V = aT + b$$

Q65. A circuit constructed using op-amp, resistor $R_1 = 1 \text{ k}\Omega$ and capacitors $C_1 = 1 \mu\text{F}$ and $C_2 = 0.1 \mu\text{F}$ is shown in the figure below.

This circuit will act as a

- (a) high pass filter
- (b) low pass filter
- (c) band pass filter
- (d) band reject filter

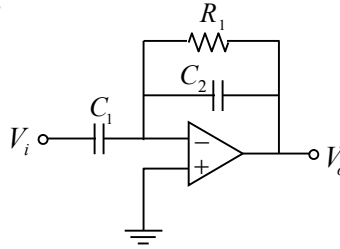

Topic- Electronics

Subtopic- Operational Amplifier

Ans.: (a)

Solution: $\frac{v_0}{v_i} = -\frac{Z_F}{Z_1} = -\frac{R_1 + X_{C_2}}{X_{C_1}} = -\frac{R_1}{R_1/X_{C_2} + 1} \times \frac{1}{1/J\omega C_1}$

$$\Rightarrow \frac{v_0}{v_i} = -\frac{R_1 j\omega C_1}{R_1 \times j\omega C_2 + 1} = \frac{R_1 \omega C_1}{\sqrt{1 + R_1^2 \omega^2 C_2^2}} \frac{e^{-j\theta_1}}{e^{j\theta_2}}$$

$$\Rightarrow \left| \frac{v_0}{v_i} \right| = \frac{R_1 \omega C_1}{\sqrt{1 + R_1^2 \omega^2 C_2^2}} = \frac{R_1 C_1}{\sqrt{1/\omega^2 + R_1^2 C_2^2}}$$

If $\omega \rightarrow 0, \left| \frac{v_0}{v_i} \right| \rightarrow 0$ and If $\omega \rightarrow \infty, \left| \frac{v_0}{v_i} \right| \rightarrow \frac{C_1}{C_2}$

Q66. The third-nearest neighbor distance in a BCC (Body Centered Cubic) crystal with lattice constant a_0 is

- (a) a_0
- (b) $\frac{3a_0}{2}$
- (c) $\sqrt{3}a_0$
- (d) $\sqrt{2}a_0$

Topic- Solid state physics

Subtopic- Crystallography

Ans.: (d)

Solution: The 1st nearest atom (I) is at distance $= \frac{\sqrt{3}a_0}{2} = 0.87a_0$

The 2nd nearest atom (II) is at distance $= a_0$

The 3rd nearest atom (III) is at distance $= \sqrt{2}a_0 = 1.414a_0$

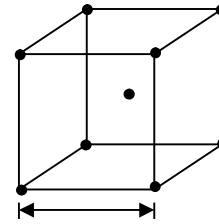

Q67. A bound electron and hole pair interacting via Coulomb interaction in a semiconductor is called an exciton. The effective masses of an electron and a hole are about $0.1m_e$ and $0.5m_e$ respectively, where m_e is the rest mass of the electron. The dielectric constant of the semiconductor is 10. Assuming that the energy levels of the excitons are hydrogen-like, the binding energy of an exciton (in units of the Rydberg constant) is closest to

- (a) 2×10^{-3} (b) 2×10^{-4} (c) 8×10^{-4} (d) 3×10^{-3}

Topic- Atomic physics
Subtopic- Binding energy

Ans.: (c)

Solution: Binding energy of exciton is $E = (13.6 eV) \frac{\mu}{m_e} \frac{1}{\epsilon^2}$

$$\text{where } \mu = \frac{m_e \times m_n}{m_e + m_n} = \frac{0.1m_e \times 0.5m_e}{0.1m_e + 0.5m_e} \Rightarrow \frac{\mu}{m_e} = 0.0833$$

$$\therefore E = 13.6 eV \times \frac{0.0833}{100} = 13.6 \times 8066 \text{ cm}^{-1} \times 8.33 \times 10^{-4} = 9.14 \text{ cm}^{-1}$$

$$\frac{E}{R_H} = \frac{9.14 \text{ cm}^{-1}}{1.097 \times 10^5 \text{ cm}^{-1}} = 8.33 \times 10^{-4}$$

Thus, correct option is (c)

Q68. Consider an array of atoms in one dimension with an ensemble averaged periodic density distribution as shown in the figure.

If k is the wave number and $S(k, \Delta)$ denotes the Fourier transform of the density-density correlation function, the ratio $\frac{S(k, \Delta)}{S(k, 0)}$ is

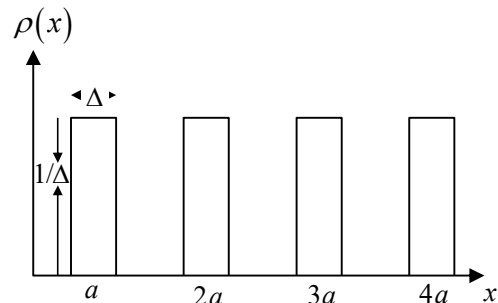

- (a) $\cos\left(\frac{k\Delta}{2}\right)$ (b) $\cos^2\left(\frac{k\Delta}{2}\right)$
 (c) $\frac{2}{k\Delta} \sin\left(\frac{k\Delta}{2}\right)$ (d) $\frac{4}{k^2\Delta^2} \sin^2\left(\frac{k\Delta}{2}\right)$

Topic- Mathematical physics
Subtopic- Fourier transform

Ans. : (c)

Solution: $\rho(x) \leftrightarrow s(k, \Delta)$ *Fourier Transform Pairs*

$$S(k, \Delta) = \sum_{n=1}^{\infty} \int_{na-\frac{\Delta}{2}}^{na+\frac{\Delta}{2}} \frac{1}{\Delta} e^{ikx} dx = \sum_{n=1}^{\infty} \frac{1}{\Delta ik} e^{ikx} \Big|_{na-\frac{\Delta}{2}}^{na+\frac{\Delta}{2}}$$

$$s(k, \Delta) = \sum_{n=1}^{\infty} \frac{1}{\Delta ik} \left[e^{ik\left(na+\frac{\Delta}{2}\right)} - e^{ik\left(na-\frac{\Delta}{2}\right)} \right]$$

$$S(k, \Delta) = \sum_{n=1}^{\infty} \frac{e^{ikna}}{\Delta ik} \frac{[e^{ik\Delta/2} - e^{-ik\Delta/2}]}{2i} 2i$$

$$= \frac{\sin k\Delta/2}{\Delta ik} \cdot 2i \sum_{k=1}^{\infty} e^{ikna} = \frac{\sin k\Delta/2}{k\Delta/2} \cdot \frac{k\Delta/2 \cdot 2i}{\Delta ik} [e^{ika} + e^{i2ka} + \dots]$$

$$S_{\infty} = \frac{e^{ika}}{1 - e^{ika}}$$

$$S(k, \Delta) = \frac{\sin k\Delta/2}{k\Delta/2} S_{\infty} \quad S(k, 0) = S_{\infty}$$

$$\frac{S(k, \Delta)}{S(k, 0)} = \frac{2 \sin k\Delta/2}{k\Delta}$$

Q69. A doubly charged ion in the angular momentum state ($J = 2, J_3 = 1$) meets a gas of polarized electrons ($S_3 = \frac{1}{2}$) and gets neutralized. If the orbital angular momentum transferred in the process is zero, the probability that the neutral atom is in the ($J = 2, J_3 = 2$) state is

- (a) $\frac{2}{5}$ (b) $\frac{2}{3}$ (c) $\frac{1}{5}$ (d) $\frac{1}{3}$

Topic- Atomic Physics
Subtopic- LS coupling

Ans. : (d)

Solution: $J_1 = 2, J_2 = 1 \Rightarrow J = |J_1 - J_2| \dots |J_1 + J_2| \Rightarrow J = 1, 2, 3$

$$m_{j_1} = -2, -1, 0, 1, 2 \text{ \& } m_{j_2} = -1, 0, 1$$

$$m = |m_{j_1} - m_{j_2}| \dots |m_{j_1} + m_{j_2}|$$

$$m = 3, 2, 1, 2, 1, 0, 1, 0, -1, 0, -1, -2, -1, -2, -3$$

$$\text{For } J = 3: m_j = -3, -2, -1, 0, 1, 2, 3$$

$$J = 2: m_j = -2, -1, 0, 1, 2$$

$$J = 1: m_j = -1, 0, 1$$

$$\text{Now } \psi |J_1, J_2; J, m\rangle = \phi |J_1, J_2; m_1, m_2\rangle$$

$$\psi |2, 1; 3, 3\rangle = \phi |2, 1; 2, 1\rangle \quad \text{_____ (1)}$$

Operating J^- to both sides:

$$J^- |J, m\rangle = \sqrt{J(J+1) - m(m-1)}\hbar |J, m-1\rangle$$

\Rightarrow Now from equation (1)

$$\psi \sqrt{12 - 6\hbar} |J, m-1\rangle = \phi \sqrt{6 - 2\hbar} |2, 1; 1, 1\rangle + \phi \sqrt{2 - 0\hbar} |2, 1; 2, 0\rangle$$

$$\sqrt{6}\psi \hbar |J, m-1\rangle = \sqrt{4}\phi \hbar |2, 1; 1, 1\rangle + \sqrt{2}\phi \hbar |2, 1; 2, 0\rangle$$

$$\psi |3, 2\rangle = \sqrt{\frac{2}{3}}\phi |2, 1; 1, 1\rangle + \sqrt{\frac{1}{3}}\phi |2, 1; 2, 0\rangle$$

As per the question, we have to find out the probability of $\phi |2, 1; 1, 1\rangle$ out of $\phi |2, 1; 3, 2\rangle$

For $m = 2$; possible m_1 & m_2 are: $|1, 1\rangle$ and $|2, 0\rangle$

$$\text{So, } \phi |2, 1; 2, 2\rangle = c_1 \phi |2, 1; 1, 1\rangle + c_2 \phi |2, 1; 2, 0\rangle$$

$$\langle \psi | \psi \rangle = 1 \Rightarrow c_1^2 + c_2^2 = 1 \quad \text{_____ (2)}$$

$$\text{Again } \Rightarrow \langle \psi (2, 1; 3, 2) | \psi (2, 1; 2, 2) \rangle = 0$$

$$\Rightarrow c_1 \sqrt{\frac{2}{3}} + c_2 \sqrt{\frac{1}{3}} = 0 \quad \text{_____ (3)}$$

$$\Rightarrow c_1 = -c_2 \sqrt{\frac{1}{2}}$$

$$\text{Putting in equation (2): } \frac{c_2^2}{2} + c_2^2 = 1 \Rightarrow c_2 = \sqrt{\frac{2}{3}} \Rightarrow c_1 = -\sqrt{\frac{1}{3}}$$

Q70. The range of the inter-atomic potential in gaseous hydrogen is approximately 5 \AA . In thermal equilibrium, the maximum temperature for which the atom-atom scattering is dominantly s -wave, is

(a) 500 K

(b) 100 K

(c) 1 K

(d) 1 mK

Topic- Classical Mechanics

Subtopic- De-Broglie Hypothesis

Ans. : (c)

Solution: The scattered wave is mainly S -wave, $ka \leq 1$, where a is interaction length between hydrogen atoms, k the de-broglie wave number.

$$k = \frac{p}{\hbar} = \frac{\sqrt{2mE_k}}{\hbar} = \frac{\sqrt{2m \cdot \frac{3}{2} k_B T}}{\hbar} = \frac{\sqrt{3mk_B T}}{\hbar}$$

$$ka = \frac{a}{\hbar} \sqrt{3mk_B T} \leq 1$$

$$\frac{a^2 3mk_B T}{\hbar^2} \leq 1 \Rightarrow T \leq \frac{\hbar^2}{3mk_B a^2}$$

$$T \leq \frac{(1.05 \times 10^{-34})^2}{3 \times 1.67 \times 10^{-27} \times 1.381 \times 10^{-23} \times (5 \times 10^{-10})^2}$$

$$T \approx \frac{1.1025 \times 10^{-68}}{172.9703 \times 10^{-70}}$$

$$T \approx 0.64k \approx 1k$$

Q71. The energy levels corresponding to the rotational motion of a molecule are $E_J = BJ(J+1)cm^{-1}$ where $J = 0, 1, 2, \dots$, and B is a constant. Pure rotational Raman transitions follow the selection rule $\Delta J = 0, \pm 2$. When the molecule is irradiated, the separation between the closest Stokes and anti-Stokes lines (in cm^{-1}) is

(a) $6B$

(b) $12B$

(c) $4B$

(d) $8B$

Topic- Molecular Physics

Subtopic- Rotational Raman Spectra

Ans.: (b)

Solution: The selection rules for Raman lines are $\Delta J = \pm 2$

$$\therefore \overline{\Delta \nu} = E_{J+2} - E_J = B(4J+6)$$

Wave number of stoke's and Anti-stoke's lines are

$$\overline{\Delta \nu}_s = \overline{\nu}_0 - \overline{\Delta \nu} = \overline{\nu}_0 - B(4J+6)$$

$$\overline{\Delta \nu}_{As} = \overline{\nu}_0 + \overline{\Delta \nu} = \overline{\nu}_0 + B(4J+6)$$

Closest separation between stokes and anti-stokes lines is

$$\overline{\Delta \nu} = \overline{\Delta \nu}_{As} - \overline{\Delta \nu}_s = 2B(4J+6) = 12B$$

Q72. The cavity of a He-Ne laser emitting at 632.8nm , consists of two mirrors separated by a distance of 35cm . If the oscillations in the laser cavity occur at frequencies within the gain bandwidth of 1.3GHz , the number of longitudinal modes allowed in the cavity is

- (a) 1 (b) 2 (c) 3 (d) 4

Topic- Molecular physics

Subtopic- Laser

Ans.: (c)

Solution: The frequency separation between two adjacent cavity mode is

$$\Delta\nu = \frac{c}{2L} = \frac{3 \times 10^8}{2 \times 35 \times 10^{-2}} = 0.42 \times 10^9 \text{ Hz} = 0.42 \text{ GHz}$$

The bandwidth is $B.W = 1.3\text{GHz}$

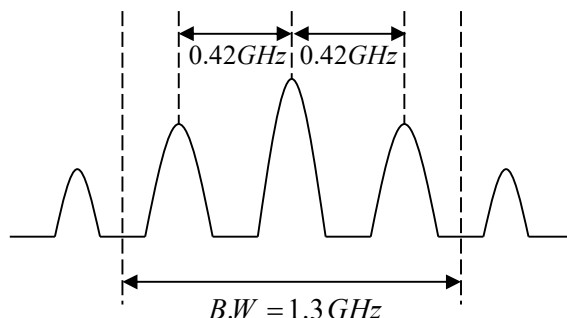

Thus, the approximate number of longitudinal laser modes within band width 1.3GHz :

$$N = \frac{1.3}{0.43} \approx 3$$

Q73. An excited state of a ${}^8_4\text{Be}$ nucleus decays into two α -particles which are in a spin-parity 0^+ state. If the mean life-time of this decay is 10^{-22}s , the spin-parity of the excited state of the nucleus is

- (a) 2^+ (b) 3^+ (c) 0^- (d) 4^-

Topic- Nuclear physics

Subtopic- Spin parity

Ans.: (a)

Solution: The parity angular momentum selection rule in α -decay says that, if the initial and final particles are same, the I_α must be even; if the parties are different, then I_α must be odd.

The ground state is 0^+ thus spin-parity of excited state must be 2^+ . Thus correct option is (a)

Q74. The elastic scattering of a neutrino ν_e by an electron e^- , i.e. the reaction $\nu_e + e^- \rightarrow \nu_e + e^-$ can be described by the interaction Hamiltonian

$$H_{\text{int}} = \frac{1}{\sqrt{2}} G_F \int d^3x (\bar{\psi}_e(x) \gamma^\mu \psi_{\nu_e}(x)) (\bar{\psi}_{\nu_e}(x) \gamma_\mu \psi_e(x))$$

The cross-section of the above process depends on the centre of mass energy E , as

- (a) $\frac{1}{E^2}$ (b) E^2 (c) E (d) \sqrt{E}

Topic- Nuclear physics

Subtopic- Interaction Hamiltonian

Ans.: (b)

Q75. The mean life-time of the following decays:

$\rho_0 \rightarrow \pi^+ + \pi^-$, $\pi^0 \rightarrow \gamma + \gamma$, $\mu^- \rightarrow e^- + \bar{\nu}_e + \nu_\mu$, are τ_ρ , τ_π and τ_μ respectively.

They satisfy

- (a) $\tau_\pi < \tau_\rho < \tau_\mu$ (b) $\tau_\mu < \tau_\rho < \tau_\pi$
(c) $\tau_\rho < \tau_\pi < \tau_\mu$ (d) $\tau_\rho < \tau_\mu < \tau_\pi$

Topic- Particle Physics

Subtopic- Mean life time

Ans.: (c)

Solution: The characteristic time for strong, electromagnetic and weak interaction are

$\approx 10^{-23}$ sec, 10^{-21} sec and 10^{-11} sec

$\rho_0 \rightarrow \pi^+ + \pi^-$ is strong interaction with $\tau_\rho \approx 10^{-23}$ sec

$\pi^0 \rightarrow \gamma + \gamma$ is electromagnetic interaction with $\tau_\pi \approx 10^{-21}$ sec

$\mu^- \rightarrow e^- + \bar{\nu}_e + \nu_\mu$ is weak interaction with $\tau_\mu \approx 10^{-11}$ sec

Thus, $\tau_\rho < \tau_\pi < \tau_\mu$. The correct option is (c)