

NET-JRF (December 2018)

PART- A

- Q1. A rectangular photo frame of size $30\text{ cm} \times 40\text{ cm}$ has a photograph mounted at the centre leaving a 5 cm border all around. The area of the border is
- (a) 600 cm^2 (b) 350 cm^2 (c) 400 cm^2 (d) 700 cm^2

Ans.: (a)

Solution: $ar(\square ABCD) = 40 \times 30$

$$ar(\square EFGH) = 30 \times 20$$

$$ar(\text{border}) = 1200 - 600 = 600\text{ cm}^2$$

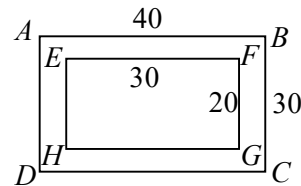

- Q2. At a birthday party, every child gets 2 chocolates, every mother gets 1 chocolate, while no father gets a chocolate. In total 69 persons get 70 chocolates. If the number of children is half of the number of mothers and fathers put together, then how many fathers are there?
- (a) 22 (b) 23 (c) 24 (d) 69

Ans.: (a)

Solution: Let numbers of child, mother 2^{nd} father be $C, M, 2^{\text{nd}} F$ respectively.

$$\text{Given, } C + M + F = 69$$

$$2C = M + F$$

$$2C + M = 70$$

Solving above we get

$$C = 23 \quad M = 29 \quad F = 22$$

- Q3. What is the value of $1^2 - 2^2 + 3^2 - 4^2 + 5^2 - \dots + 17^2 - 18^2 + 19^2$?
- (a) -5 (b) 12 (c) 95 (d) 190

Ans.: (d)

Solution: $S = 1^2 - 2^2 + 3^2 - 4^2 + 5^2 - 6^2 + \dots + 17^2 - 18^2 + 19^2$

$$S = (1-2)(1+2) + (3-4)(3+4) + (5-6)(5+6) + \dots + (17-18)(17+18) + 19$$

$$= -[3 + 7 + \dots + 35] + 19^2 = -\frac{9}{2}(3+35) + 19^2 = 190$$

- Q4. The curves of $y = 2x^2$ and $y = 4x$ intersect each other at
- (a) only one point (b) exactly two points
(c) more than two points (d) no point at all

Ans.: (b)

Solution: At the point of Intersections

$$2x^2 = 4x$$

$$\text{or, } x(2x - 4) = 0$$

$$\text{or, } x = 0, \text{ or } x = 2$$

so, two points of Intersections.

- Q5. The diameters of the pinholes of two otherwise identical cameras A and B are $500 \mu\text{m}$ and $200 \mu\text{m}$, respectively. Then the image in camera A will be
- (a) sharper than in B (b) darker than in B
(c) less sharp and brighter than in B (d) sharper and brighter than in B

Ans.: (c)

Solution: smaller the perture diameter, qretha the shorpuse of $2u$ image.

- Q6. If $D = ABC + BCA + CAB$, where A, B and C are decimal digits, then D is divisible by
- (a) 37 and 29 (b) 37 but not 29
(c) 29 but not 37 (d) neither 29 nor 37

Ans.: (b)

$$\text{Solution: } D = (100A + 10B + C) + (100B + 10C + A) + (100C + 10A + B)$$

$$= 111A + 111B + 111C = 111(A + B + C)$$

$$= 37 \times 3 \times (A + B + C)$$

- Q7. For the following set of observed values

$$\{60, 65, 65, 70, 70, 70, 70, 82, 85, 90, 95, 95, 100, 160, 160\}$$

which of the statements is true?

- (a) mode < median < mean (b) mode < mean < median
(c) mean < median < mode (d) median < mode < mean

Ans.: (a)

Solution: Given set of observed values is:

60, 65, 65, 70, 70, 70, 70, 82, 85, 90, 95, 95, 100, 160, 160

Total observed values = 15

Median = 82 (21st position)

Mode = 70 (observed values with highest frequency)

$$\text{Mean} = \frac{1337}{15} \approx 89$$

Q8. A circular running track has six lanes, each 1 m wide. How far ahead (in meters) should the runner in the outermost lane start from, so as to cover the same distance in one lap as the runner in the innermost lane?

- (a) 6π (b) 10π (c) 12π (d) 36π

Ans.: (b)

Solution: Let track radius r m

Then last track radius = $r + 5$ m

$$\text{So, required lead} = 2\pi(r + 5) - 2\pi r \text{ m} = 10\pi$$

Q9. In an examination 100 questions of 1 mark each are given. After the examination, 20 questions are deleted from evaluation, leaving 80 questions with a total of 100 marks. Student A had answered 4 of the deleted questions correctly and got 40 marks, whereas student B had answered 10 of the deleted questions correctly and got 35 marks. In this situation

- (a) A and B were equally benefited (b) A and B lost equally
(c) B lost more than A (d) A lost more than B

Ans.: (c)

Solution: Out of 80 questions,

$$A's \text{ correct numbers of solutions} = \frac{40}{100} = 32$$

$$B's \text{ correct numbers of solution} = \frac{35}{100} = 28$$

Had 20 questions not been deleted,

$$A's \text{ total correct solutions} = 32 + 4$$

$$B's \text{ total correct solution} = 28 + 10 = 38$$

Q10. A tourist drives 20 km towards east, turns right and drives 6 km, then drives 6 km towards west. He then turns to his left and drives 4 km and finally turns right and drives 14 km. Where is he from his starting point?

- (a) 6 km towards east (b) 20 km towards west
(c) 14 km towards north (d) 10 km towards south

Ans.: (d)

Solution: from figure, it is evident that he is 10 km towards south

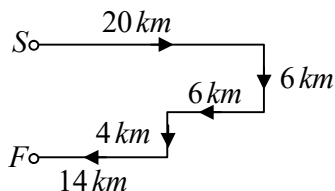

Q11. If 'SELDOON' means 'NOODLES' then what does 'SPUOS' mean?

- (a) SALAD (b) SOUPS (c) RASAM (d) ONION

Ans.: (b)

Solution: Interchanging first alphabet with last one, we get NOODLES from SELDOON. Similarly,

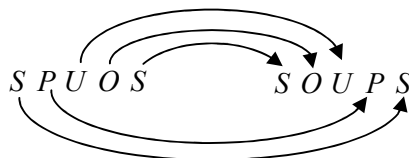

Q12. An ideal pendulum oscillates with angular amplitude of 30° from the vertical. If it is observed at a random instant of time, its angular deviation from the vertical is most likely to be

- (a) 0° (b) ±10° (c) ±20° (d) ±30°

Ans.: (d)

Q13. In the context of tiling a plane surface, which of the following polygons is the odd one out?

- (a) Equilateral triangle (b) Square
(c) Regular pentagon (d) Regular hexagon

Ans.: (c)

Solution: While tiling a plane surface, there must be n polygonous all of item neety at each vertex

point, this implies the interior angle of each of these must be $\frac{2\pi}{n}$, when a is a positive integer

for $u = 5$ (Peutas'ou)

We here interior angle = $\frac{2\pi}{5}$, which is not possible for a regular polygou. : Not possible.

For $u = 3$ (hexagous)

This will need to wave three regular hexagous need at real vertex.: Possible

For $u = 4$ (squares)

This has four squares neatly at each vertex: Possible

For $u = 6$ (equilateral triangle)

In this case polyxgous need to have angles = $\frac{2\pi}{6} = \frac{\pi}{3}$

So this tiling will have six triangles neetily at each vertex.: Possible

Q14. Scatter plots for pairs of observations on the variables x and y in samples A and B are shown in the figure.

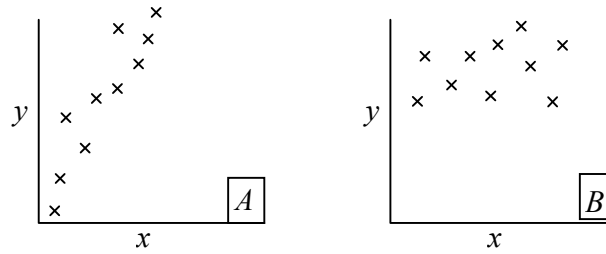

Which of the following is suggested by the plots?

- (a) Correlation between x and y is stronger in A than in B
- (b) Correlation between x and y is absent in B
- (c) Correlation between x and y is weaker in A than in B
- (d) y and x have a cause - effect relationship in A but not in B

Ans.: (a)

Solution: as there is positive correlation the simple A while little or no is simple B

Q15. Two solutions X and Y containing ingredients A, B and C in proportions $a:b:c$ and $c:b:a$, respectively, are mixed. For the resultant mixture to have A, B and C in equal proportion, it is necessary that

- (a) $b = \frac{c-a}{2}$ (b) $c = \frac{a+b}{2}$ (c) $c = \frac{a-b}{2}$ (d) $b = \frac{c+a}{2}$

Ans.: (d)

Solution: Let x unit of X 2nd y units of Y are mixed together.

Then in resultant solution:

$$A = \frac{ax + cy}{a + b + c} \quad (i)$$

$$B = \frac{bx + by}{a + b + c} \quad (ii)$$

$$C = \frac{cx + ay}{a + b + c} \quad (iii)$$

If A, B and C are equal, then solving (i) and (iii)

We get $x = y$

Also, as $A = B = C$, this implies

$$\frac{ax + cy}{a + b + c} = \frac{bx + by}{a + b + c}$$

putting $x = y$, we obtain,

$$a + c = b + b$$

$$\text{or, } b = \frac{a + c}{2}$$

Q16. Find the missing figure in the following sequence.

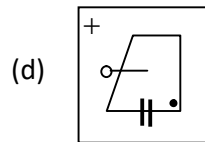
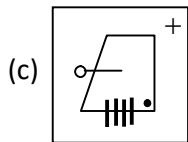
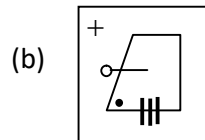
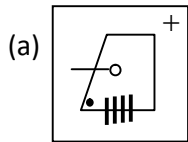
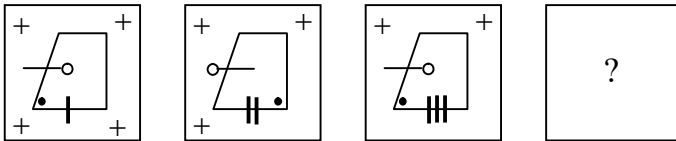

Ans.: (c)

Solution: It is obvious from the trend of the figures that the missing figure will have one '+' and '←'. So the correct choice is (c).

Q17. In triangle ABC , $AB = 11$, $BC = 61$, $AC = 60$, and O is the mid-point of BC . Then AO is

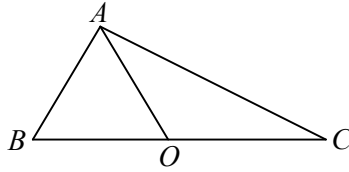

- (a) 18.5 (b) 24.0 (c) 30.5 (d) 36.0

Ans.: (c)

Solution: It is obvious the given triangle is a right triangle as $10^2 + 60^2 = 61^2$, with $\angle A = \frac{\pi}{2}$.

From the property of a right angled triangle:

$$AO = OB = OC$$

If O is mid-point of hypotenuse.

$$\text{So, } AO = \frac{61}{2} = 30.5$$

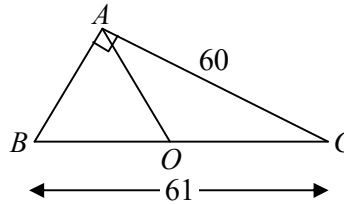

Q18. Areas of three parts of a rectangle are given in unit of cm^2 . What is the total area of the rectangle?

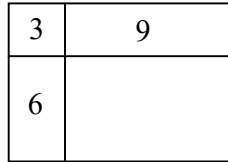

- (a) 18 (b) 24 (c) 36 (d) 108

Ans.: (c)

Solution: From figure:

$$2y = 3 \quad \text{(i)}$$

$$(l-x)y = 9 \quad \text{(ii)}$$

$$(b-y)x = 6 \quad \text{(iii)}$$

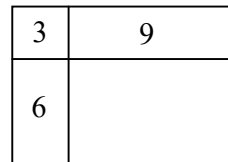

$$(l-x)(b-x) = \text{Area of missing portion.}$$

$$\text{(ii) } \times \text{ (iii)} \Rightarrow (l-x)(b-x)xy = 54$$

$$\text{from (i): } xy = 3$$

$$\text{so, } (l-x)(b-x) = 18 \quad \text{(Area of miss portion)}$$

$$\text{So, Total area} = 3 + 9 + 6 + 18 = 36$$

2nd method :

$$\frac{8}{6} = \frac{9}{\text{area of missing portion}}$$

or, area of missing portion = $\frac{9 \times 6}{3} = 18$

So, Total area = $3 + 9 + 6 + 18 = 36$

Q19. A student is free to choose only Chemistry, only Biology or both. If out of 32 students, Chemistry has been chosen by 16 and Biology by 25, then how many students have chosen Biology but not Chemistry?

- (a) 9 (b) 16 (c) 25 (d) 7

Ans.: (b)

Solution: $n(C) = 16 =$ number of chemistry students

$$n(B) = 25 = \text{number of biology students}$$

$$n(C \cup B) = n(C) + n(B) - n(C \cap B)$$

or, $n(C \cap B) = 9$

so, number of students with biology but not chemistry

$$= n(B) - n(C \cap B) = 25 - 9 = 16$$

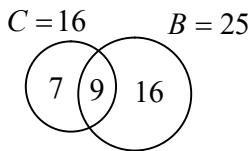

Q20. The lift (upward force due to air) generated by the wings and engines of an aircraft is

- (a) positive (upwards) while landing and negative (downwards) while taking off.
 (b) negative (downwards) while landing and positive (upwards) while taking off
 (c) negative (downwards) while landing as well as while taking off
 (d) positive (upwards) while landing as well as while taking off

Ans.: (d)

PART B

Q21. One of the eigenvalues of the matrix e^A is e^a , where $A = \begin{pmatrix} a & 0 & 0 \\ 0 & 0 & a \\ 0 & a & 0 \end{pmatrix}$. The product of the other two eigenvalues of e^A is

Topic – Mathematical Physics

Subtopic - Matrix

- (a) e^{2a} (b) e^{-a} (c) e^{-2a} (d) 1

Ans.: (d)

Solution: Eigenvalues of matrix A are a, a and $-a$. The product of two other eigenvalues of A are

$$e^a e^{-a} = 1$$

Alternatively

$$\text{Trace } e^A = e^{\lambda_1 + \lambda_2 + \lambda_3} = \det e^A$$

$$\Rightarrow e^{\lambda_1} \cdot e^{\lambda_2 + \lambda_3} = \det e^A \Rightarrow e^a \cdot e^{\lambda_2} \cdot e^{\lambda_3} = e^a$$

$$\Rightarrow e^{\lambda_2} \cdot e^{\lambda_3} = 1$$

Q22. The polynomial $f(x) = 1 + 5x + 3x^2$ is written as linear combination of the Legendre polynomials

$\left(p_0(x) = 1, p_1(x), p_2(x) = \frac{1}{2}(3x^2 - 1) \right)$ as $f(x) = \sum_n c_n p_n(x)$. The value of c_0 is

Topic – Mathematical Physics

Subtopic – Special function

- (a) $\frac{1}{4}$ (b) $\frac{1}{2}$ (c) 2 (d) 4

Ans.: (c)

Solution: $f(x) = 1 + 5x + 3x^2$

$$1 = p_0(x), \quad x = p_1(x) \quad \text{and} \quad x^2 = \frac{1}{3}(2p_2(x) + 1)$$

$$f(x) = p_0(x) + 5p_1(x) + 2p_2(x) + p_0(x)$$

$$= 2p_0(x) + 5p_1(x) + 2p_2(x)$$

$$= c_0 p_0(x) + c_1 p_1(x) + c_2 p_2(x) \quad \Rightarrow c_0 = 2$$

Q23. The value of the integral $\oint_C \frac{dz \tanh 2z}{z \sin \pi z}$, where C is a circle of radius $\frac{\pi}{2}$, traversed counter-clockwise, with centre at $z = 0$, is

Topic – Mathematical Physics

Subtopic – Complex analysis

- (a) 4 (b) $4i$ (c) $2i$ (d) 0

Ans.:

Solution: $\oint_C \frac{dz \tanh 2z}{z \sin \pi z} dz$

$$z = 0, 1, -1, \frac{\pi^2}{4}, -\frac{\pi^2}{4}$$

$$f(z) = \frac{2z - \frac{1}{3}(2z)^3 + \frac{2}{15}(2z)^5 \dots}{z \left(\pi z - \frac{\pi^2 z^2}{3!} + \dots \right)}$$

$$\frac{2}{\pi z} \left(1 - \frac{1}{2} z^2 + \dots \right) \left(1 - \frac{\pi^2 z^2}{2!} + \dots \right)$$

$$b_1 = \frac{2}{\pi}$$

$$\frac{\tanh^2}{-\pi} = -\frac{1}{\pi} \left(2 \cosh \frac{\pi^2}{4} \right)$$

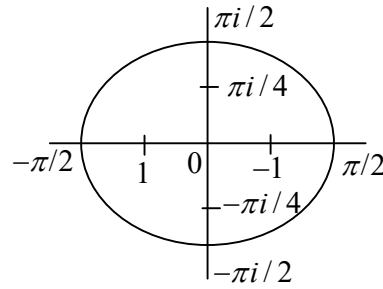

Q24. A particle of mass m , moving along the x -direction, experiences a damping force $-\gamma v^2$, where γ is a constant and v is its instantaneous speed. If the speed at $t = 0$ is v_0 , the speed at time t is

- (a) $v_0 e^{-\frac{\gamma v_0 t}{m}}$ (b) $\frac{v_0}{1 + \ln \left(1 + \frac{\gamma v_0 t}{m} \right)}$
- (c) $\frac{m v_0}{m + \gamma v_0 t}$ (d) $\frac{2 v_0}{1 + e^{\frac{\gamma v_0 t}{m}}}$

Ans.: (c)

Solution: From Newton's second law

$$m \frac{dv}{dt} = -xv^2 \Rightarrow \frac{dv}{v^2} = -\frac{x}{m} dt$$

Integrating both sides gives $-\frac{1}{v} = -\frac{x}{m}t + c$

where c is a constant of integration

Since $v = v_0$ at $t = 0$, we obtain

$$-\frac{1}{v_0} = -\frac{x}{m} \cdot 0 + c \Rightarrow c = -\frac{1}{v_0}$$

Hence, $-\frac{1}{v} = -\frac{x}{m}t - \frac{1}{v_0}$

$$\Rightarrow \frac{1}{v} = \frac{xt}{m} + \frac{1}{v_0} = \frac{xv_0t + m}{mv_0} \Rightarrow v = \frac{mv_0}{xv_0t + m} = \frac{mv_0}{m + xv_0t}$$

- Q25. The integral $I = \int_C e^z dz$ is evaluated from the point $(-1, 0)$ to $(1, 0)$ along the contour C , which is an arc of the parabola $y = x^2 - 1$, as shown in the figure.

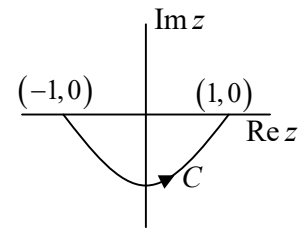

The value of I is

Topic – Mathematical Physics

Subtopic – Complex analysis

- (a) 0 (b) $2 \sinh 1$ (c) $e^{2i} \sinh 1$ (d) $e + e^{-1}$

Ans.: (b)

Solution: $\oint_C f(z) dz = 2\pi i \epsilon R \Rightarrow \int_C f(z) dz + \int_1^{-1} e^x dx = 0$

$$\int_C f(z) dz = -\int_1^{-1} e^x dx = \int_1^{-1} e^x dx = \frac{(e^1 - e^{-1})}{2} \cdot 2 = 2 \sinh 1$$

- Q26. In terms of arbitrary constants A and B , the general solution to the differential equation

$$x^2 \frac{d^2 y}{dx^2} + 5x \frac{dy}{dx} + 3y = 0 \text{ is}$$

Topic – Mathematical Physics

Subtopic – Differential Equations

- (a) $y = \frac{A}{x} + Bx^3$ (b) $y = Ax + \frac{B}{x^3}$

(c) $y = Ax + Bx^3$

(d) $y = \frac{A}{x} + \frac{B}{x^3}$

Ans.: (d)

Solution: The given equation is Euler-Cauchy differential equation. The characteristic equation of

$$x^2 \frac{d^2 y}{dx^2} + 5x \frac{dy}{dx} + 6y = 0$$

is $m^2 + 4m + 6 = 0 \Rightarrow m = -3$ or $m = -1$

Thus, $y_1 = x^{-1} = \frac{1}{x}$ and $y_2 = x^{-3} = \frac{1}{x^3}$

Therefore the general solution is

$$y = \frac{A}{x} + \frac{B}{x^3}$$

Q27. In the attractive Kepler's problem described by the central potential $V(r) = \frac{-k}{r}$ (where k is a positive constant), a particle of mass m with a non-zero angular momentum can never reach the centre due to the centrifugal barrier. If we modify the potential to

$$V(r) = -\frac{k}{r} - \frac{\beta}{r^3}$$

one finds that there is a critical value of the angular momentum ℓ_c below which there is no centrifugal barrier. This value of ℓ_c is

Topic – Classical Mechanics

Subtopic – Central force problem

(a) $[12km^2\beta]^{1/2}$ (b) $[12km^2\beta]^{-1/2}$ (c) $[12km^2\beta]^{1/4}$ (d) $[12km^2\beta]^{-1/4}$

Ans.: (c)

Solution:
$$v_{\text{eff}} = \frac{L^2}{2mr^2} - \frac{k}{r} - \frac{\beta}{r^3} = 0$$

$$-\frac{L^2}{mr^3} + \frac{k}{r^2} = 0 \Rightarrow r_0 = \frac{L^2}{mk}$$

When introduce new potential

$$v_{\text{eff}} = \frac{L^2}{2mr^2} - \frac{k}{r} - \frac{\beta}{r^3}$$

for critical value

$$\frac{\partial v_{eff}}{\partial r} = \frac{-L^2}{mr^3} + \frac{k}{r^2} + \frac{3\beta}{r^4}$$

$$\frac{\partial^2 v_{eff}}{\partial r^2} = \frac{+3L^2}{mr^4} - \frac{2k}{r^3} - \frac{12\beta}{r^5} \geq 0$$

For critical value $\frac{3L^2}{m\left(\frac{L^2}{mk}\right)^4} - \frac{2k}{\left(\frac{L^2}{mk}\right)^3} - \frac{12\beta}{\left(\frac{L^2}{mk}\right)^5} = 0$

$$= \frac{3L^2}{m\left(\frac{L^2}{mk}\right)^4} - \frac{2k}{\left(\frac{L^2}{mk}\right)^3} - \frac{12\beta}{\left(\frac{L^2}{mk}\right)^5} = 0 = \frac{3m^3k^4}{L^6} - \frac{2m^3x^4}{L^6} - \frac{12m^5x^5\beta}{L^{10}} = 0$$

$$L_C = (12m^2k\beta)^{1/4} \frac{m^3k^4}{L^6} \left(3 - 2 - 12\frac{m^2k\beta}{L^4}\right) = 0 \Rightarrow L = (12m^2k\beta)^{1/4}$$

Q28. The time period of a particle of mass m , undergoing small oscillations around $x = 0$, in the potential $v = v_0 \cosh\left(\frac{x}{L}\right)$, is

Topic – Classical mechanics

Subtopic – Small Oscillations

(a) $\pi \sqrt{\frac{mL^2}{v_0}}$ (b) $2\pi \sqrt{\frac{mL^2}{2v_0}}$ (c) $2\pi \sqrt{\frac{mL^2}{v_0}}$ (d) $2\pi \sqrt{\frac{2mL^2}{v_0}}$

Ans.: (c)

Solution: $v = v_0 \cosh\left(\frac{x}{L}\right)$

For equilibrium point $\frac{\partial v}{\partial x} = 0 \Rightarrow \frac{v_0}{L} \sinh\left(\frac{x}{L}\right) = 0$

$$k = \left. \frac{\partial^2 v}{\partial x^2} \right|_{x=0} = \frac{v_0}{L^2}$$

$$\omega = \sqrt{\frac{k}{m}} \Rightarrow \frac{2\pi}{T} = \sqrt{\frac{v_0}{mL^2}} \Rightarrow T = 2\pi \sqrt{\frac{mL^2}{v_0}}$$

Q29. Consider the decay $A \rightarrow B + C$ of a relativistic spin- $\frac{1}{2}$ particle A . Which of the following statements is true in the rest frame of the particle A ?

(a) The spin of both B and C may be $\frac{1}{2}$

- (b) The sum of the masses of B and C is greater than the mass of A
- (c) The energy of B is uniquely determined by the masses of the particles
- (d) The spin of both B and C may be integral

Topic – Classical Mechanics

Subtopic – Special theory of Relativity

Ans. : (c)

Q30. Two current-carrying circular loops, each of radius R , are placed perpendicular to each other, as shown in the figure.

The loop in the xy - plane carries a current I_0 while that in the xz - plane carries a current $2I_0$. The resulting magnetic field \vec{B} at the origin is

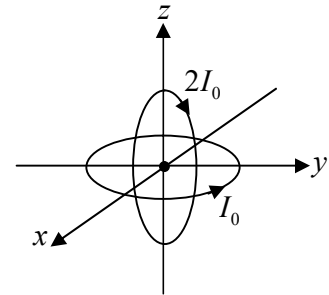

Topic – Electromagnetic theory

Subtopic – Gauss theorem

- | | |
|--------------------------------------------------|--------------------------------------------------|
| (a) $\frac{\mu_0 I_0}{2R} [2\hat{j} + \hat{k}]$ | (b) $\frac{\mu_0 I_0}{2R} [2\hat{j} - \hat{k}]$ |
| (c) $\frac{\mu_0 I_0}{2R} [-2\hat{j} + \hat{k}]$ | (d) $\frac{\mu_0 I_0}{2R} [-2\hat{j} - \hat{k}]$ |

Ans.: (c)

Solution: Field due to loop in xy plane is $\vec{B}_1 = \frac{\mu_0 I_0}{2R} \hat{z}$

Field due to loop in xz plane is

$$\vec{B}_2 = \frac{\mu_0 (2I_0)}{2R} (-\hat{y})$$

$$\text{Resultant field } \vec{B} = \vec{B}_1 + \vec{B}_2 = \frac{\mu_0 I_0}{2R} (-2\hat{y} + \hat{z})$$

Q31. An electric dipole of dipole moment $\vec{P} = qb\hat{i}$ is placed at origin in the vicinity of two charges $+q$ and $-q$ at (L, b) and $(L, -b)$, respectively, as shown in the figure below.

The electrostatic potential at the point $(\frac{L}{2}, 0)$ is

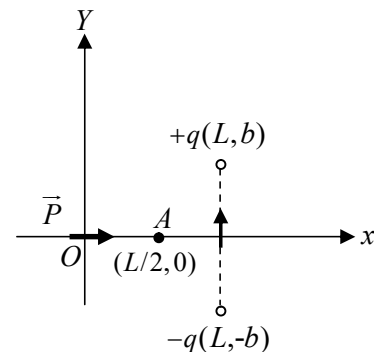

Topic – Electromagnetic theory

Subtopic – Electrostatic Potential

(a) $\frac{qb}{\pi \epsilon_0} \left(\frac{1}{L^2} + \frac{2}{L^2 + 4b^2} \right)$

(b) $\frac{4qbL}{\pi \epsilon_0 [L^2 + 4b^2]^{3/2}}$

(c) $\frac{qb}{\pi \epsilon_0 L^2}$

(d) $\frac{3qb}{\pi \epsilon_0 L^2}$

Ans.: (c)

Solution: Potential due to dipole $V_1 = \frac{1}{4\pi\epsilon_0} \frac{p \cos 0^\circ}{(L/2)^2} = \frac{1}{\pi\epsilon_0} \frac{p}{L^2}$

Potential due to $+q$ charge $V_2 = \frac{1}{4\pi\epsilon_0} \frac{q}{\sqrt{L^2/4 + b^2}}$

Potential due to $-q$ charge $V_3 = \frac{1}{4\pi\epsilon_0} \frac{q}{\sqrt{L^2/4 + b^2}}$

Resultant $V = V_1 + V_2 + V_3 = \frac{1}{\pi\epsilon_0} \frac{p}{L^2} \Rightarrow V = \frac{1}{\pi\epsilon_0} \frac{qb}{L^2}$

Hence, correct option is (c)

Q32. A monochromatic and linearly polarized light is used in a Young's double slit experiment. A linear polarizer, whose pass axis is at an angle 45° to the polarization of the incident wave, is placed in front of one of the slits. If I_{\max} and I_{\min} , respectively, denote the maximum and minimum intensities of the interference pattern on the screen, the visibility, defined as the ratio $\frac{I_{\max} - I_{\min}}{I_{\max} + I_{\min}}$, is

Topic – Optics

Subtopic – Young's double slit

(a) $\frac{\sqrt{2}}{3}$

(b) $\frac{2}{3}$

(c) $\frac{2\sqrt{2}}{3}$

(d) $\sqrt{\frac{2}{3}}$

Ans.: (c)

Solution: $I_1 = I_0 = A_0^2$

$$I_2 = I_0 \cos^2 45 = \frac{I_0}{2} = \left(\frac{A_0}{\sqrt{2}} \right)^2$$

$$\frac{I_{\max} - I_{\min}}{I_{\max} + I_{\min}} = \frac{4a_1 a_2}{2(a_1^2 + a_2^2)} = \frac{2a_1 / a_2}{a_1^2 / a_2^2 + 1} = \frac{2A_0 / A_0 / \sqrt{2}}{A_0^2 / A_0^2 + 1} = \frac{2\sqrt{2}}{3}$$

- Q33. An electromagnetic wave propagates in a nonmagnetic medium with relative permittivity $\epsilon = 4$. The magnetic field for this wave is

$$\vec{H}(x, y) = \hat{k} H_0 \cos(\omega t - \alpha x - \alpha\sqrt{3}y)$$

Where H_0 is a constant. The corresponding electric field $\vec{E}(x, y)$ is

Topic – Electromagnetic theory

Subtopic – EM Wave

- (a) $\frac{1}{4} \mu_0 H_0 c (-\sqrt{3}\hat{i} + \hat{j}) \cos(\omega t - \alpha x - \alpha\sqrt{3}y)$
 (b) $\frac{1}{4} \mu_0 H_0 c (\sqrt{3}\hat{i} + \hat{j}) \cos(\omega t - \alpha x - \alpha\sqrt{3}y)$
 (c) $\frac{1}{4} \mu_0 H_0 c (\sqrt{3}\hat{i} - \hat{j}) \cos(\omega t - \alpha x - \alpha\sqrt{3}y)$
 (d) $\frac{1}{4} \mu_0 H_0 c (-\sqrt{3}\hat{i} - \hat{j}) \cos(\omega t - \alpha x - \alpha\sqrt{3}y)$

Ans.: (a)

Solution: $\vec{E} = -v(\hat{K} \times \hat{B})$

$$\vec{K} = \alpha\hat{x} + \alpha\sqrt{3}\hat{y} \Rightarrow \hat{K} = \frac{\vec{K}}{|\vec{K}|} = \frac{\alpha\hat{x} + \alpha\sqrt{3}\hat{y}}{\sqrt{\alpha^2 + 3\alpha^2}} = \frac{1}{2}\hat{x} + \frac{\sqrt{3}}{2}\hat{y}$$

$$\Rightarrow E = \frac{-c}{\sqrt{\epsilon_r}} \left[\frac{\hat{x} + \sqrt{3}\hat{y}}{2} \times \mu_0 H_0 \cos(\omega t - \alpha x - \alpha\sqrt{3}y) \hat{z} \right]$$

$$= \frac{-c\mu_0 H_0}{2\sqrt{4}} \left[(-\hat{y} + \sqrt{3}\hat{x}) \cos(\omega t - \alpha x - \alpha\sqrt{3}y) \right]$$

$$= \frac{1}{4} c\mu_0 H_0 (-\sqrt{3}\hat{x} + \hat{y}) \cos(\omega t - \alpha x - \alpha\sqrt{3}y)$$

- Q34. The ground state energy of an anisotropic harmonic oscillator described by the potential

$$V(x, y, z) = \frac{1}{2} m\omega^2 x^2 + 2m\omega^2 y^2 + 8m\omega^2 z^2 \text{ (in units of } \hbar\omega \text{) is}$$

Topic – Quantum mechanics

Subtopic – Harmonic oscillator

- (a) $\frac{5}{2}$ (b) $\frac{7}{2}$ (c) $\frac{3}{2}$ (d) $\frac{1}{2}$

Ans.: (b)

Solution: $v(x, y, z) = \frac{1}{2}m\omega^2 x^2 + \frac{1}{2}m(2\omega)^2 y^2 + \frac{1}{2}m(4\omega)^2 z^2$

$\omega_x = \omega \quad \omega_y = 2\omega \quad \omega_z = 4\omega$

$E_{n_x, n_y, n_z} = \left(n_x + \frac{1}{2}\right)\hbar\omega_x + \left(n_y + \frac{1}{2}\right)\hbar\omega_y + \left(n_z + \frac{1}{2}\right)\hbar\omega_z$

For ground state

$n_x = 0, n_y = 0, n_z = 0$

$= \frac{1}{2}\hbar\omega + \frac{1}{2}\hbar 2\omega + \frac{1}{2}\hbar 4\omega = \frac{1}{2}\hbar\omega(1+2+4) = \frac{7}{2}\hbar\omega$

Q35. The product $\Delta x \Delta p$ of uncertainties in the position and momentum of a simple harmonic oscillator of mass m and angular frequency ω in the ground state $|0\rangle$, is $\frac{\hbar}{2}$. The value of the product $\Delta x \Delta p$ in the state, $e^{-i\hat{p}\ell/\hbar}|0\rangle$ (where ℓ is a constant and \hat{p} is the momentum operator) is

Topic – Quantum mechanics

Subtopic – Harmonic oscillator

- (a) $\frac{\hbar}{2} \sqrt{\frac{m\omega\ell^2}{\hbar}}$ (b) \hbar (c) $\frac{\hbar}{2}$ (d) $\frac{\hbar^2}{m\omega\ell^2}$

Ans.: (c)

Q36. Let the wavefunction of the electron in a hydrogen atom be

$$\psi(\vec{r}) = \frac{1}{\sqrt{6}}\phi_{200}(\vec{r}) + \sqrt{\frac{2}{3}}\phi_{21-1}(\vec{r}) - \frac{1}{\sqrt{6}}\phi_{100}(\vec{r})$$

where $\phi_{nlm}(\vec{r})$ are the eigenstates of the Hamiltonian in the standard notation. The expectation value of the energy in this state is

Topic – Quantum mechanics

Subtopic – Hydrogen atom

- (a) -10.8 eV (b) -6.2 eV (c) -9.5 eV (d) -5.1 eV

Ans.: (d)

Solution: $\psi = \frac{1}{\sqrt{6}} \phi_{2,0,0} + \sqrt{\frac{2}{3}} \phi_{2,1,-1} - \frac{1}{\sqrt{6}} \phi_{(1,0,0)}$

$$p\left(\frac{-13.6}{4}\right) = \frac{1}{6} + \frac{2}{3} = \frac{1+4}{6} = \frac{5}{6}$$

$$p(-3.4) = \frac{5}{6}$$

$$p(-13.6) = \frac{1}{6}$$

$$\langle E \rangle = (-3.4) \times \frac{5}{6} + (-13.6) \times \frac{1}{6} = \frac{1}{6}(-17.00 - 13.6) \text{ eV} = -\frac{30.60}{6} = -5.1 \text{ eV}$$

Q37. Three identical spin $\frac{1}{2}$ particles of mass m are confined to a one-dimensional box of length L , but are otherwise free. Assuming that they are non-interacting, the energies of the lowest two energy eigen states, in units of $\frac{\pi^2 \hbar^2}{2mL^2}$, are

- (a) 3 and 6 (b) 6 and 9 (c) 6 and 11 (d) 3 and 9

Topic – Quantum mechanics

Subtopic – Identical particles

Ans.: (b)

Solution: put $\frac{\pi^2 \hbar^2}{2ml^2} = E_0$

For ground state configuration 2 particle has engine E_0 and 1 particle has engine $4E_0$

Total energy is $2 \times E_0 + 1 \times 4E_0 = 6E_0$

For first excited state configuration 1 particles has engine E_0 and 2 particle has engine $4E_0$

Total energy $1 \times E_0 + 2 \times 4E_0 = 9E_0$

Lowest two energy levels are $6E_0, 9E_0$ where $E_0 = \frac{\pi^2 \hbar^2}{2ml^2}$

Q38. The heat capacity C_V at constant volume of a metal, as a function of temperature, is $\alpha T + \beta T^3$, where α and β are constant. the temperature dependence of the entropy at constant volume is

Topic – Solid state physics

Subtopic – Heat capacity

(a) $\alpha T + \frac{1}{3} \beta T^3$

(b) $\alpha T + \beta T^3$

(c) $\frac{1}{2} \alpha T + \frac{1}{3} \beta T^3$

(d) $\frac{1}{2} \alpha T + \frac{1}{4} \beta T^3$

Ans.: (a)

Solution: $C_V = \alpha T + \beta T^3$

$$dS = \frac{dQ}{T} = \frac{C_V dT}{T}$$

$$\int dS = \int (\alpha + \beta T^2) dT$$

$$S = \alpha T + \frac{1}{3} \beta T^3$$

Q39. The rotational energy levels of a molecule are $E_\ell = \frac{\hbar^2}{2I_0} \ell(\ell+1)$, where $\ell = 0, 1, 2, \dots$ and I_0 is its moment of inertia. The contribution of the rotational motion to the Helmholtz free energy per molecule, at low temperatures in a dilute gas of these molecules, is approximately

Topic – Molecular Physics

Subtopic – Rotational spectra

(a) $-k_B T \left(1 + \frac{\hbar^2}{I_0 k_B T} \right)$

(b) $-k_B T e^{-\frac{\hbar^2}{I_0 k_B T}}$

(c) $-k_B T$

(d) $-3k_B T e^{-\frac{\hbar^2}{I_0 k_B T}}$

Ans.: (d)

Solution: $E_\ell = \frac{\hbar^2}{2I_0} \ell(\ell+1) \quad \ell = 0, 1, 2, \dots$

$$z = \sum_{\ell=0}^{\infty} (2\ell+1) e^{-\frac{\beta \hbar^2 \ell(\ell+1)}{2I_0}}$$

$$z = 1 + \sum_{\ell=0}^{\infty} (2\ell+1) e^{-\frac{\hbar^2 \ell(\ell+1)}{2I_0 k_B T}}$$

$$F = -k_B T \ln z = -k_B T \ln \left(1 + \sum_{\ell=1}^{\infty} (2\ell+1) e^{\frac{-\hbar^2 \ell(\ell+1)}{2I_0 k_B T}} \right)$$

$$\ln(1+x) = x - \frac{x^2}{2} + \dots$$

For low temp higher temps can be neglected

$$F = -k_B T \sum_{\ell=1}^{\infty} (2\ell+1) e^{\frac{-\hbar^2 \ell(\ell+1)}{2I_0 k_B T}} = -k_B T \left[3 e^{\frac{-\hbar^2}{I_0 k_B T}} + \dots \right] = -3k_B T e^{\frac{-\hbar^2}{I_0 k_B T}}$$

Q40. The vibrational motion of a diatomic molecule may be considered to be that of a simple harmonic oscillator with angular frequency ω . If a gas of these molecules is at temperature T , what is the probability that a randomly picked molecule will be found in its lowest vibrational state?

Topic – Statistical mechanics

Subtopic – Probability

(a) $1 - e^{-\frac{\hbar\omega}{k_B T}}$

(b) $e^{-\frac{\hbar\omega}{2k_B T}}$

(c) $\tanh\left(\frac{\hbar\omega}{k_B T}\right)$

(d) $\frac{1}{2} \operatorname{cosec} h\left(\frac{\hbar\omega}{2k_B T}\right)$

Ans.: (a)

Solution: $E = \left(n + \frac{1}{2}\right) \hbar\omega \quad n = 0, 1, 2, \dots$

$$z = e^{-\frac{\hbar\omega}{2k_B T}} + e^{-\frac{3\hbar\omega}{2k_B T}} + e^{-\frac{5\hbar\omega}{2k_B T}} + \dots$$

$$P(G.S.) = \frac{e^{-\frac{\hbar\omega}{2k_B T}}}{e^{-\frac{\hbar\omega}{2k_B T}} + e^{-\frac{3\hbar\omega}{2k_B T}} + \dots} = \frac{e^{-\frac{\hbar\omega}{2k_B T}}}{e^{-\frac{\hbar\omega}{2k_B T}} \left(1 + e^{-\frac{\hbar\omega}{k_B T}} + \dots \right)} = \frac{1}{1 + e^{-\frac{\hbar\omega}{k_B T}}} = 1 - e^{-\frac{\hbar\omega}{k_B T}}$$

Q41. Consider an ideal Fermi gas in a grand canonical ensemble at a constant chemical potential. The variance of the occupation number of the single particle energy level with mean occupation number \bar{n} is

Topic – Statistical mechanics

Subtopic – grand canonical ensemble

(a) $\bar{n}(1-\bar{n})$

(b) $\sqrt{\bar{n}}$

(c) \bar{n}

(d) $\frac{1}{\sqrt{n}}$

Ans.: (a)

Solution: $\bar{n} = k_B T \frac{1}{z} \left(\frac{\partial z}{\partial \mu} \right)_{V,T} = \frac{1}{e^{(\epsilon-\mu)/k_B T} + 1}$

Variance = $k_B T \left(\frac{d\bar{n}}{d\mu} \right)_{V,T} \bar{n}(1-\bar{n})$

Note: This may also be derived using simple Binomial distribution

Q42. Consider the following circuit, consisting of an RS flip-flop and two AND gates.

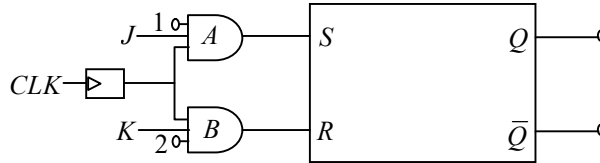

Which of the following connections will allow the entire circuit to act as a JK flip-flop?

Topic – Electronics

Subtopic – Digital electronics

(a) Connect Q to pin 1 and \bar{Q} to pin 2

(b) Connect Q to pin 2 and \bar{Q} to pin 1

(c) Connect Q to K input and \bar{Q} to J input

(d) Connect Q to J input and \bar{Q} to K input

Ans.: (b)

Q43. The truth table below gives the value $Y(A, B, C)$ where A, B and C are binary variables.

A	B	C	Y
0	0	0	1
0	0	1	0
0	1	0	0
0	1	1	1
1	0	0	1
1	1	0	0
1	1	1	1

The output Y can be represented by

Topic – Electronics

Subtopic – K-Map

(a) $Y = \bar{A}\bar{B}C + \bar{A}B\bar{C} + A\bar{B}C + ABC$

(b) $Y = \bar{A}\bar{B}\bar{C} + \bar{A}BC + A\bar{B}\bar{C} + ABC$

(c) $Y = \bar{A}\bar{B}C + \bar{A}BC + A\bar{B}C + ABC$

(d) $Y = \bar{A}\bar{B}\bar{C} + \bar{A}B\bar{C} + A\bar{B}\bar{C} + ABC$

Ans.: (b)

Solution: $Y = \bar{A}\bar{B}\bar{C} + \bar{A}BC + A\bar{B}\bar{C} + ABC$

Q44. A sinusoidal signal is an input to the following circuit

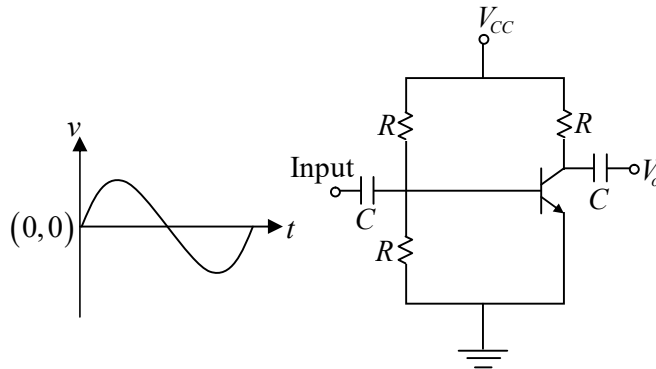

Which of the following graphs best describes the output wave function?

Topic – Electronics

Subtopic – Transistor

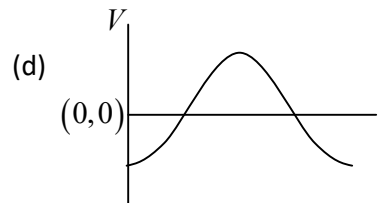
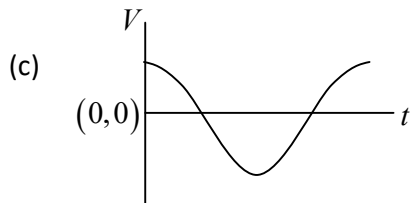
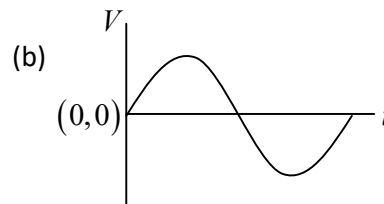
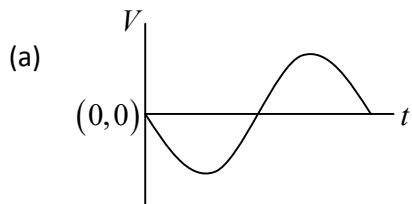

Ans.: (a)

Solution: In CE transistor output has phase change of π

Q45. A sinusoidal voltage having a peak value of V_p is an input to the following circuit, in which the DC voltage is V_b

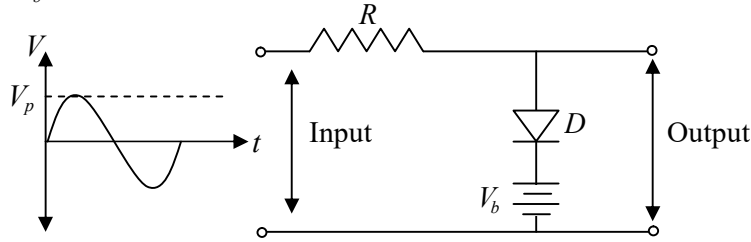

Assuming an ideal diode which of the following best describes the output waveform?

Topic – Electronics

Subtopic – Network analysis

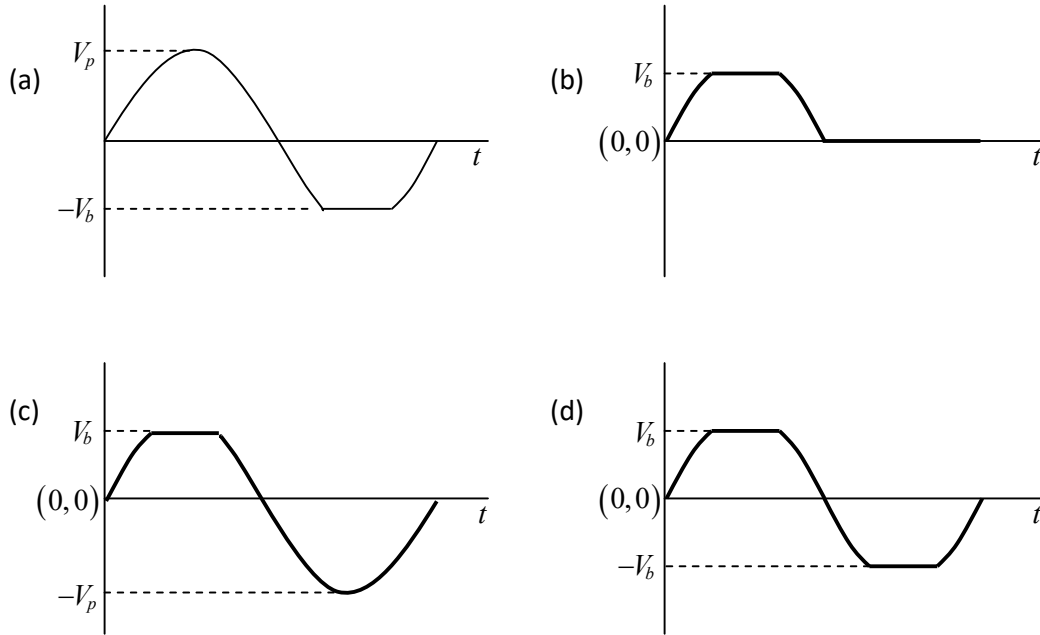

Ans.: (c)

PART C

Q46. The Green's function $G(x, x')$ for the equation $\frac{d^2 y(x)}{dx^2} = f(x)$, with the boundary values

$y(0) = 0$ and $y(1) = 0$, is

$$(a) G(x, x') = \begin{cases} \frac{1}{2}x(1-x), & 0 < x < x' < 1 \\ \frac{1}{2}x'(1-x) & 0 < x' < x < 1 \end{cases}$$

$$(b) G(x, x') = \begin{cases} x(x'-1), & 0 < x < x' < 1 \\ x'(1-x) & 0 < x' < x < 1 \end{cases}$$

$$(c) G(x, x') = \begin{cases} -\frac{1}{2}x(1-x'), & 0 < x < x' < 1 \\ \frac{1}{2}x'(1-x) & 0 < x' < x < 1 \end{cases}$$

$$(d) G(x, x') = \begin{cases} x(x'-1), & 0 < x < x' < 1 \\ x'(x-1) & 0 < x' < x < 1 \end{cases}$$

Topic – Mathematical Physics

Subtopic – Green’s theorem

Ans.: (d)

Solution: $\frac{d^2y}{dx^2} = f(x)$

$$p(x') = 1$$

$$x_1 = 1, y_2 = x$$

$$y_1 = x, y_2 = 1 - x \quad w = \begin{vmatrix} x & 1-x \\ 1 & -1 \end{vmatrix} = -1$$

$$A = -1$$

$$G(x, x') = \begin{cases} A y_1 y_2' = \begin{cases} x & (x'-1) & 0 < x < x' < 1 \\ x' & (x-1) & 0 < x' < x < 1 \end{cases} \end{cases}$$

Q47. A 4×4 complex matrix A satisfies the relation $A^\dagger A = 4I$, where I is the 4×4 identity matrix.

The number of independent real parameters of A is

- (a) 32 (b) 10 (c) 12 (d) 16

Topic – Mathematical physics

Subtopic – Matrix

Ans. : (d)

Solution: Given that $A^\dagger A = 4I \Rightarrow \frac{1}{4}(A^\dagger A) = I$

Let $A = 2B$ then

$$A^\dagger = 2B^\dagger$$

Therefore, $B^\dagger B = I$

This shows that B is an unitary matrix. The number of independent real parameters needed to specify an $n \times n$ unitary matrix is n^2 . Thus the number of independent parameter needed to specify matrix B is $4^2 = 16$.

Now the number of independent parameters needed to specify matrix A is same as that of matrix B .

Thus the number of independent parameters needed to specify A is 16

Q48. The contour C of the following integral

$$\oint_C dz \frac{\sqrt{(z-1)(z-3)}}{(z^2-25)^3}$$

is the complex z plane is shown in the figure below.

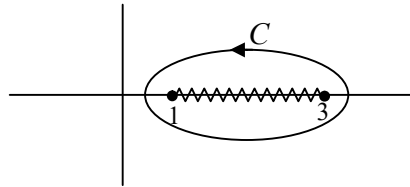

This integral is equivalent to an integral along the contours

Topic – Mathematical physics

Subtopic – Complex analysis

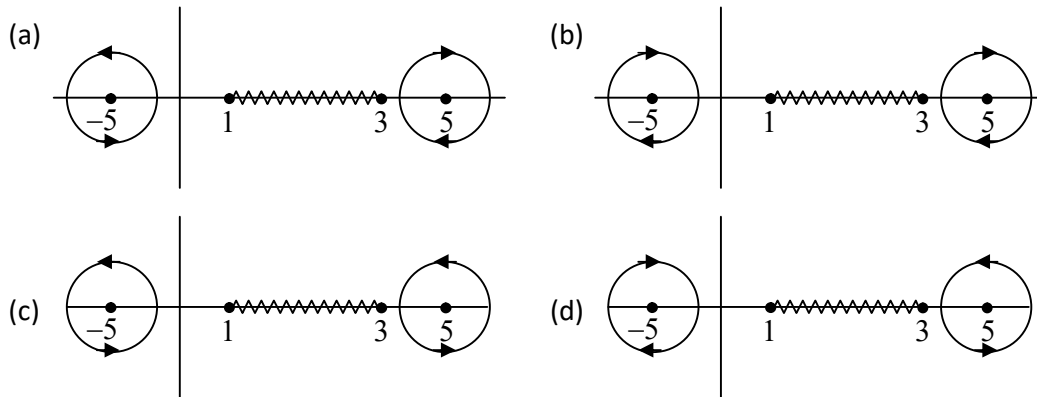

Ans.: (c)

Solution: $z = 1, 3$ are branch points ∞ is not a branch point 1 branch cut 3

Q49. The value of the integral $\int_0^1 x^2 dx$, evaluated using the trapezoidal rule with a step size of 0.2, is

- (a) 0.30 (b) 0.39 (c) 0.34 (d) 0.27

Topic – Mathematical physics

Subtopic – Simpson’s rule

Ans.: (c)

Solution:

	x	$f(x)$
x_0	0	0
x_1	0.2	0.04
x_2	0.4	0.16
x_3	0.6	0.36
x_4	0.8	0.64
x_5	1.0	1.00

$$I = \frac{0.2}{2} [0 + 2(0.04 + 0.16 + 0.36 + 0.64) + 1] = 0.1(2.4 + 1) = 0.34$$

Q50. The motion of a particle in one dimension is described by the Lagrangian $L = \frac{1}{2} \left(\left(\frac{dx}{dt} \right)^2 - x^2 \right)$ in suitable units. The value of the action along the classical path from $x = 0$ at $t = 0$ to $x = x_0$ at $t = t_0$, is

Topic – Classical mechanics

Subtopic – Lagrangian

- (a) $\frac{x_0^2}{2 \sin^2 t_0}$ (b) $\frac{1}{2} x_0^2 \tan t_0$ (c) $\frac{1}{2} x_0^2 \cot t_0$ (d) $\frac{x_0^2}{2 \cos^2 t_0}$

Ans.: (c)

Solution: $L = \frac{1}{2} \dot{x}^2 - \frac{1}{2} x^2 \quad \frac{d}{dt} \left(\frac{\partial L}{\partial \dot{x}} \right) - \frac{\partial L}{\partial x} = 0$

$$\ddot{x} + x = 0$$

The solution is $x = A \sin t + B \cos t$

$$t = 0 \quad x = 0 \quad B = 0$$

$$x = A \sin t$$

$$t = t_0 \quad x = x_0 \quad A = \frac{x_0}{\sin t_0}$$

$$x = \frac{x_0}{\sin t_0} \sin t, \quad \dot{x} = \frac{x_0}{\sin t_0} \cos t$$

$$\begin{aligned} Ldt &= \int_0^{t_0} \frac{1}{2} \dot{x}^2 dt - \int_0^{t_0} \frac{1}{2} x^2 dt = \frac{1}{2} \frac{x_0^2}{\sin^2 t_0} \int_0^{t_0} \cos^2 t dt - \frac{1}{2} \frac{x_0^2}{\sin^2 t_0} \int_0^{t_0} \sin^2 t dt \\ &= \frac{1}{2} \frac{x_0^2}{\sin^2 t_0} \left[\int_0^{t_0} \cos^2 t dt - \int_0^{t_0} \sin^2 t dt \right] = \frac{1}{2} \frac{x_0^2}{\sin^2 t_0} \frac{\sin 2t_0}{2} \Big|_0^{t_0} = \frac{x_0^2}{2} \cot t_0 \end{aligned}$$

Q51. The Hamiltonian of a classical one-dimensional harmonic oscillator is

$$H = \frac{1}{2}(p^2 + x^2), \text{ in suitable units. The total time derivative of the dynamical variable } (p + \sqrt{2}x) \text{ is}$$

Topic – Classical mechanics

Subtopic – Poisson bracket

- (a) $\sqrt{2}p - x$ (b) $p - \sqrt{2}x$ (c) $p + \sqrt{2}x$ (d) $x + \sqrt{2}p$

Ans.: (a)

Solution: $H = \frac{p^2}{2} + \frac{x^2}{2}$ Let say dynamical variable $A = (p + \sqrt{2}x)$

$$\begin{aligned} \frac{dA}{dt} &= \left[p + \sqrt{2}x, \frac{p^2}{2} + \frac{x^2}{2} \right] = \left[p, \frac{x^2}{2} \right] + \left[\sqrt{2}x, \frac{p^2}{2} \right] \\ &= \frac{-2x}{2} + \frac{\sqrt{2}2p}{2} = -x + \sqrt{2}p = \sqrt{2}p - x \end{aligned}$$

Q52. A relativistic particle of mass m and charge e is moving in a uniform electric field of strength ε .

Starting from rest at $t = 0$, how much time will it take to reach the speed $\frac{c}{2}$?

Topic – Classical mechanics

Subtopic – Special theory of relativity

- (a) $\frac{1}{\sqrt{3}} \frac{mc}{e\varepsilon}$ (b) $\frac{mc}{e\varepsilon}$ (c) $\sqrt{2} \frac{mc}{e\varepsilon}$ (d) $\sqrt{\frac{3}{2}} \frac{mc}{e\varepsilon}$

Ans.: (a)

Solution: $\frac{dp}{dt} = eE$

$$p = eEt + c$$

at $t = 0$ $p = 0$ $c = 0$

$$\frac{mv}{\sqrt{1 - \frac{v^2}{c^2}}} = eEt$$

$$t = \frac{m}{eE} \frac{v}{\sqrt{1 - \frac{v^2}{c^2}}}$$

put $v = \frac{c}{2}$

$$t = \frac{m}{eE} \frac{\frac{c}{2}}{\sqrt{1 - \frac{1}{4}}} = \frac{mc}{\sqrt{3}eE} \quad t = \frac{mc}{\sqrt{3}eE}$$

Q53. In an inertial frame uniform electric and magnetic field \vec{E} and \vec{B} are perpendicular to each other and satisfy $|\vec{E}|^2 - |\vec{B}|^2 = 29$ (in suitable units). In another inertial frame, which moves at a constant velocity with respect to the first frame, the magnetic field is $2\sqrt{5}\hat{k}$. In the second frame, an electric field consistent with the previous observations is

Topic – Classical mechanics

Subtopic – Special theory of relativity

- (a) $\frac{7}{\sqrt{2}}(\hat{i} + \hat{j})$ (b) $7(\hat{i} + \hat{k})$ (c) $\frac{7}{\sqrt{2}}(\hat{i} + \hat{k})$ (d) $7(\hat{i} + \hat{j})$

Ans.: (a)

Solution: $|\vec{E}|^2 - |\vec{B}|^2 = 29$ in another Frame

$$|\vec{E}|^2 - |\vec{B}|^2 = 29$$

$$\vec{B} = 2\sqrt{5}\hat{k} \quad |B| = 4 \times 5 = 20 \quad |\vec{E}|^2 = 49$$

it is given $\vec{E} \perp \vec{B}$ so $\vec{E} = \frac{7}{\sqrt{2}}(\hat{i} + \hat{j})$

Q54. Electromagnetic wave of angular frequency ω is propagating in a medium in which, over a band of frequencies the refractive index is $n(\omega) \approx 1 - \left(\frac{\omega}{\omega_0}\right)^2$, where ω_0 is a constant. The ratio $\frac{v_g}{v_p}$ of the group velocity to the phase velocity at $\omega = \frac{\omega_0}{2}$ is

Topic – Electromagnetic theory
Subtopic – Electromagnetic wave

- (a) 3 (b) $\frac{1}{4}$ (c) $\frac{2}{3}$ (d) 2

Ans.: (a)

Solution: $n = 1 - \frac{\omega^2}{\omega_0^2}$

$$n = \frac{c}{v_p} = 1 - \frac{\omega_0^2/4}{\omega_0^2} = \frac{3}{4} \Rightarrow v_p = \frac{4c}{3}$$

$$n = \frac{ck}{\omega} = 1 - \frac{\omega^2}{\omega_0^2} \Rightarrow kc = \omega - \frac{\omega^3}{\omega_0^2}$$

$$\Rightarrow \frac{dk}{d\omega} \cdot c = 1 - \frac{3\omega^2}{\omega_0^2} = 1 - 3 \frac{\omega_0^2/4}{\omega_0^2} = \frac{1-3}{4} = -\frac{1}{4} \Rightarrow v_g = \frac{d\omega}{dk} = 4c$$

Thus, $\frac{v_g}{v_p} = \frac{4c}{4c/3} = 3$

Q55. A rotating spherical shell of uniform surface charge and mass density has total mass M and charge Q . If its angular momentum is L and magnetic moment is μ , then the ratio $\frac{\mu}{L}$ is

Topic – Classical mechanics
Subtopic – Moment of inertia

- (a) $\frac{Q}{3M}$ (b) $\frac{2Q}{3M}$ (c) $\frac{Q}{2M}$ (d) $\frac{3Q}{4M}$

Ans.: (c)

Solution: $I = \frac{2}{3}MR^2, L = I\omega = \frac{2}{3}MR^2\omega$ $\sigma = \frac{Q}{4\pi R^2}$

$$dm = dI \times \pi (R \sin \theta)^2 = \frac{\sigma \times (2\pi R \sin \theta)(R d\theta) \times \pi R^2 \sin^2 \theta}{2\pi / \omega}$$

$$dm = \pi\sigma\omega R^4 \sin^3 \theta d\theta$$

$$\mu = \int dm = \frac{4}{3} \pi\sigma\omega R^4 = \frac{4}{3} \pi \left(\frac{\theta}{4\pi R^2} \right) \omega R^4$$

$$\mu = \frac{QR^2\omega}{3}$$

$$\frac{\mu}{L} = \frac{QR^2\omega/3}{\frac{2}{3}MR^2\omega} = \frac{QR^2\omega}{3} \times \frac{3}{2MR^2\omega} = \frac{Q}{2M}$$

Q56. Consider the operator $A_x = L_y p_z - L_z p_y$, where L_i and p_i denote, respectively, the components of the angular momentum and momentum operators. The commutator $[A_x, x]$, where x is the x -component of the position operator, is

Topic – Quantum mechanics

Subtopic – Commutation relation

(a) $-i\hbar(zp_z + yp_y)$

(b) $-i\hbar(zp_z - yp_y)$

(c) $i\hbar(zp_z + yp_y)$

(d) $i\hbar(zp_z - yp_y)$

Ans.: (a)

Solution: $A_x = L_y P_z - L_z P_y$ $L_y = zP_x - xP_z$ $L_z = xP_y - yP_x$

$$\begin{aligned} [A_x, x] &= [L_y P_z, x] - [L_z P_y, x] = [L_y, x] P_z - [L_z, x] P_y \\ &= [zP_x, x] P_z + [yP_x, x] P_y = z[P_x, x] P_z + y[P_x, x] P_y \\ &= -i\hbar zP_z + 0i\hbar yP_y = -i\hbar(zP_z + yP_y) \end{aligned}$$

Q57. A one-dimensional system is described by the Hamiltonian $H = \frac{p^2}{2m} + \lambda|x|$ (where $\lambda > 0$). The ground state energy varies as a function of λ as

Topic – Classical mechanics

Subtopic – Bohr sommerfeld theory

(a) $\lambda^{5/3}$

(b) $\lambda^{2/3}$

(c) $\lambda^{4/3}$

(d) $\lambda^{1/3}$

Ans.: (a)

Solution: using Bohr Sommerfeld theory

$$\oint P dx = nk = 4 \int_0^{x_0 = \frac{E}{\lambda}} \sqrt{2m(E - \lambda x)} dx$$

where x_0 is turning point $x_0 = \frac{E}{\lambda}$

$$\Rightarrow 4 \times \sqrt{2mE} \times \frac{E}{\lambda} \int_0^1 \sqrt{1-t} dt = nh$$

$$\frac{E^{3/2}}{\lambda} \propto n$$

$$E \propto \lambda^{2/3}$$

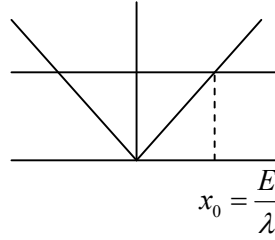

Q58. If the position of the electron in the ground state of a Hydrogen atom is measured, the probability that it will be found at a distance $r \geq a_0$ (a_0 being Bohr radius) is nearest to

Topic – Electronics

Subtopic – Digital electronics

- (a) 0.91 (b) 0.66 (c) 0.32 (d) 0.13

Ans.: (b)

Solution: $P(a_0 \leq r < \infty) = \int_{a_0}^{\infty} r^2 |R_{10}|^2 dr$

$$R_{10} = \frac{2}{a_0^{3/2}}$$

$$P(a_0 \leq r < \infty) = \frac{4}{a_0^3} \int_{a_0}^{\infty} r^2 e^{-\frac{2r}{a_0}} dr = 0.66$$

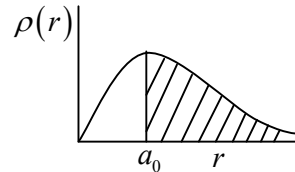

Q59. A system of spin $\frac{1}{2}$ particles is prepared to be in the eigenstate of σ_z with eigenvalue +1. The system is rotated by an angle of 60° about the x -axis. After the rotation, the fraction of the particles that will be measured to be in the eigenstate of σ_z with eigenvalue +1 is

Topic – Quantum mechanics

Subtopic – Identical particles

- (a) $\frac{1}{3}$ (b) $\frac{2}{3}$ (c) $\frac{1}{4}$ (d) $\frac{3}{4}$

Ans.: (d)

Solution: Rotational with angle θ about x axis

$$U[R(\theta)] = \exp\left(-i\theta \frac{\sigma}{2}\right)$$

$$U[R(\theta)] = \cos\left(\frac{\theta}{2}\right)I - i \sin\left(\frac{\theta}{2}\right)\hat{\theta} \cdot \sigma$$

$$U[R_x(\theta)] = \cos\frac{\theta}{2}I - i \sin\left(\frac{\theta}{2}\right)\hat{\theta} \cdot \sigma_x$$

$$R_x(\theta) = \begin{pmatrix} \cos\frac{\theta}{2} & i \sin\frac{\theta}{2} \\ -i \sin\frac{\theta}{2} & \cos\frac{\theta}{2} \end{pmatrix} \quad \text{Put } \theta = \frac{\pi}{3}$$

$$|\psi(\theta)\rangle = R_x(\theta) \begin{pmatrix} 1 \\ 0 \end{pmatrix} = \begin{pmatrix} \frac{\sqrt{3}}{2} & \frac{i}{2} \\ -\frac{i}{2} & \frac{\sqrt{3}}{2} \end{pmatrix} \begin{pmatrix} 1 \\ 0 \end{pmatrix}$$

$$|\psi\rangle = \begin{pmatrix} \frac{\sqrt{3}}{2} \\ \frac{i}{2} \end{pmatrix} = \frac{\sqrt{3}}{2} \begin{pmatrix} 1 \\ 0 \end{pmatrix} - \frac{i}{2} \begin{pmatrix} 0 \\ 1 \end{pmatrix}$$

if σ_z is measure on $|\psi\rangle$ the measure +1 with probability $\frac{3}{4}$ and -1 with probability $\frac{1}{4}$

Q60. The Hamiltonian of a one-dimensional Ising model of N spins (N large) is

$$H = -J \sum_{i=1}^N \sigma_i \sigma_{i+1}$$

where the spin $\sigma_i = \pm 1$ and J is a positive constant. At inverse temperature $\beta = \frac{1}{k_B T}$, the

correlation function between the nearest neighbor spins ($\sigma_i \sigma_{i+1}$) is

Topic – Statistical mechanics

Subtopic – Ising model

(a) $\frac{e^{-\beta J}}{(e^{\beta J} + e^{-\beta J})}$

(b) $e^{-2\beta J}$

(c) $\tan h(\beta J)$

(d) $\cot h(\beta J)$

Ans.: (c)

Solution: $\langle \sigma_i \cdot \sigma_{i+1} \rangle = \frac{\sum \sigma_i \cdot \sigma_{i+1}}{N-1} = \frac{\sum \sigma_i \cdot \sigma_{i+1}}{N} N \gg 1 = \frac{1-1}{-jN}$ (i)

For such Ising model for $N \gg 1$

$$z = (\cosh \beta j)^N$$

$$\text{Average Energy} = \frac{-\partial}{\partial \beta} \ln z$$

$$= -N \frac{1}{\cosh \beta j} \sinh \beta j \cdot j \quad \text{(ii)}$$

$$\langle \sigma_i \cdot \sigma_{i+1} \rangle = \frac{-Nj \tanh \beta j}{-jN} = \tanh \beta j$$

Q61. At low temperatures, in the Debye approximation, the contribution of the phonons to the heat capacity of a two dimensional solid is proportional to

Topic – Solid state physics

Subtopic – Specific heat

- (a) T^2 (b) T^3 (c) $T^{1/2}$ (d) $T^{3/2}$

Ans.: (a)

Solution: The dispersion relation of phonons is $\omega = AK$

The phonon specific heat is d -dimension is $C_V \propto T^d$

For 2 dimensional solid $d = 2$

$$C_V \propto T^d$$

Q62. A particle hops on a one-dimensional lattice with lattice spacing a . The probability of the particle to hop to the neighboring site to its right is p , while the corresponding probability to hop to the left is $q = 1 - p$. The root-mean squared deviation $\Delta x = \sqrt{\langle x \rangle^2 - \langle x \rangle^2}$ in displacement after N steps, is

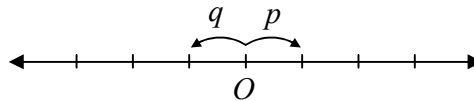

Topic – Statistical mechanics

Subtopic – Random walk problem

- (a) $a\sqrt{Npq}$ (b) $aN\sqrt{pq}$ (c) $2a\sqrt{Npq}$ (d) $a\sqrt{N}$

Ans. : (c)

Q63. The energy levels accessible to a molecule have energies $E_1 = 0, E_2 = \Delta$ and $E_3 = 2\Delta$ (where Δ is a constant). A gas of these molecules is in thermal equilibrium at temperature T . The specific heat at constant volume in the high temperature limit ($k_B T \gg \Delta$) varies with temperature as

Topic – Statistical mechanics

Subtopic – Canonical ensemble

- (a) $\frac{1}{T^{3/2}}$ (b) $\frac{1}{T^3}$ (c) $\frac{1}{T}$ (d) $\frac{1}{T^2}$

Ans. : (d)

Q64. The input V_i to the following circuit is a square wave as shown in the following figure.

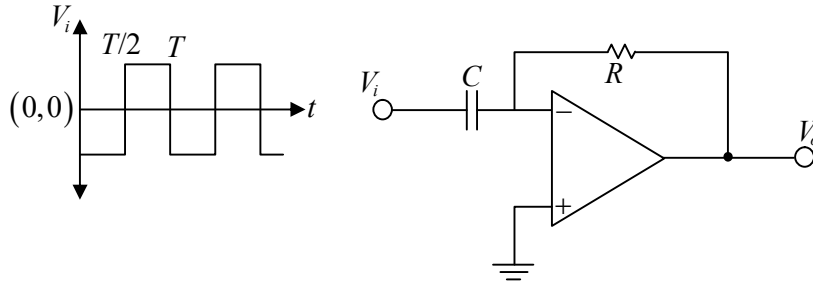

which of the waveforms best describes the output?

Topic – Electronics

Subtopic – Amplifier

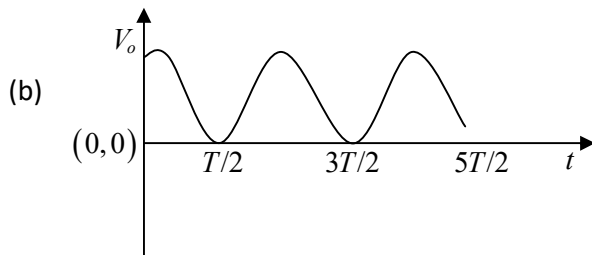
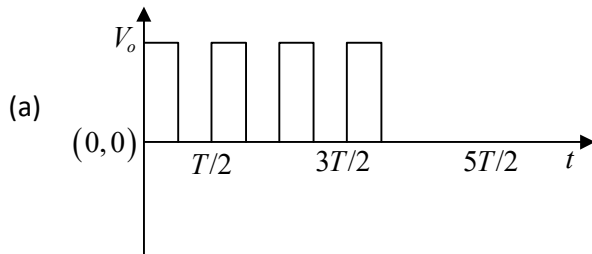

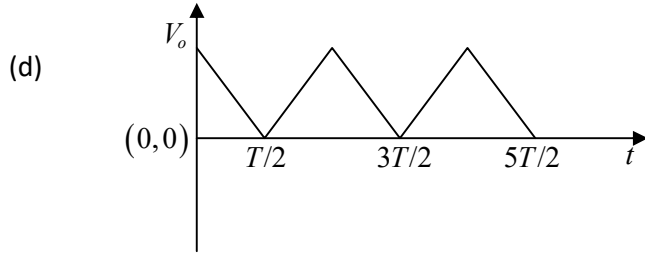
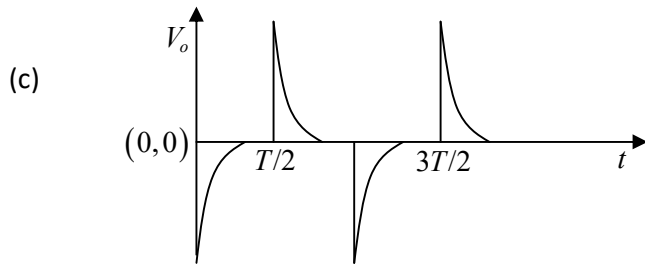

Ans.: (c)

Solution: Differentiator

Q65. The amplitude of a carrier signal of frequency f_0 is sinusoidally modulated at a frequency $f' \ll f_0$. Which of the following graphs best describes its power spectrum?

Topic – Mathematical physics

Subtopic – Fourier transform

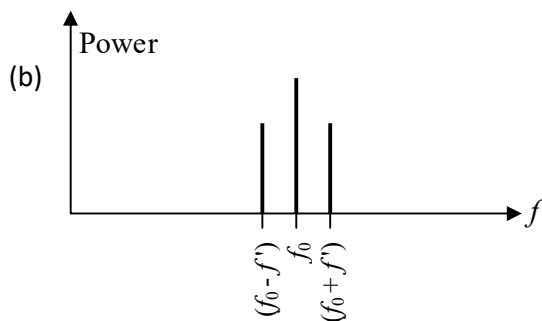
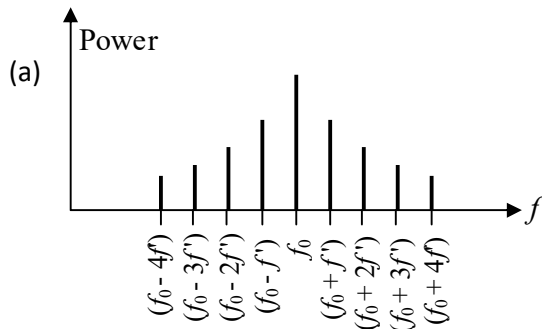

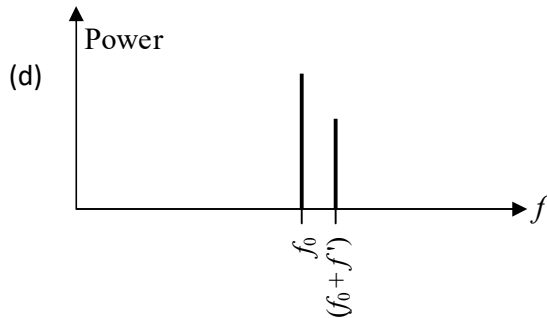
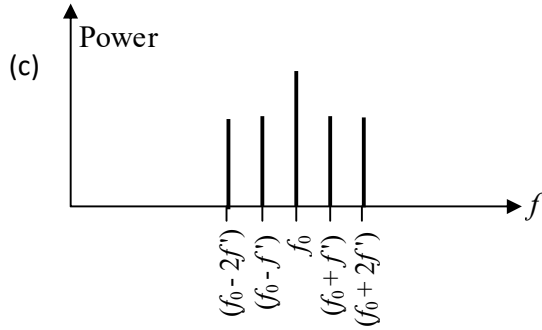

Ans.: (b)

Solution: $2 \sin A \cos B = \sin(A+B) + \sin(A-B)$

$C(t) = A \sin(2\pi ft)$ - Carrier wave

$M(t) = M \cos(2\pi f_0 t)$ - Modulation waveform = $Am \cos(2\pi f_0 t)$

Amplitude modulated wave $y(t) = \left[1 + \frac{M(t)}{A}\right] C(t)$

$$y(t) = A \sin(2\pi ft) + \frac{Am}{2} \sin[2\pi(f+f_0)t] + \frac{Am}{2} \sin[2\pi(f-f_0)t]$$

Q66. The standard deviation of the following set of data

$\{10.0, 10.0, 9.9, 9.9, 9.8, 9.9, 9.9, 9.9, 9.8, 9.9\}$ is nearest to

Topic – Mathematical physics

Subtopic – Standard deviation

(a) 0.10

(b) 0.07

(c) 0.01

(d) 0.04

Ans.: (b)

Solution: x $x_i - \bar{x}$ $(x_i - \bar{x})^2$

10.0 0.1 0.01

10.0	0.1	0.01
9.9	0	0
9.9	0	0
9.8	-0.1	0.01
9.9	0	0
9.9	0	0
9.9	0	0
9.8	0.1	0.01
9.9	0	0
99		0.04

Where $\bar{x} = \frac{\sum x}{N} = \frac{99}{10} = 9.9$

$$\sigma = \sqrt{\frac{\sum (x_i - \bar{x})^2}{N-1}} = \sqrt{\frac{0.04}{9}} = 0.066$$

$\therefore \sigma = 0.07$

Q67. The diatomic molecule HF has an absorption line in the rotational band at 40 cm^{-1} for the isotope ^{18}F . The corresponding line for the isotope ^{19}F will be shifted by approximately

Topic – Molecular Physics

Subtopic – Rotational spectra

- (a) 0.05 cm^{-1} (b) 0.11 cm^{-1} (c) 0.33 cm^{-1} (d) 0.01 cm^{-1}

Ans. : (b)

Solution: For $^1\text{HF}^{18}$: $2B_1 = 40 \text{ cm}^{-1} \Rightarrow B_1 = 20 \text{ cm}^{-1}$ and reduce mass is $\mu_1 = \frac{1 \times 18}{1+18} = \frac{18}{19}$

For $^1\text{HF}^{19}$: The reduce mass is $\mu_2 = \frac{1 \times 19}{1+19} = \frac{19}{20}$ and rotational constant is B_2

Since, $\frac{B_2}{B_1} = \frac{\mu_1}{\mu_2}$

$$\therefore B_2 = \frac{\mu_1}{\mu_2} \times B_1 = \frac{18}{19} \times \frac{20}{19} \times 20 \text{ cm}^{-1} = 19.945 \text{ cm}^{-1}$$

Thus, $2B_2 = 39.889 \text{ cm}^{-1}$

Shift in spectral line = $2B_1 - 2B_2 = 40 - 39.889 = 0.11 \text{ cm}^{-1}$

Q68. The excited state ($n = 4, l = 2$) of an electron in an atom may decay to one or more of the lower energy levels shown in the diagram below.

$$n = 4 \quad \overline{\quad} \\ l = 2$$

$$n = 3 \quad \overline{\quad} \quad \overline{\quad} \quad \overline{\quad} \\ l = 0 \quad l = 1 \quad l = 2$$

$$n = 2 \quad \overline{\quad} \\ l = 1$$

Of the total emitted light, a fraction $\frac{1}{4}$ comes from the decay to the state ($n = 2, l = 1$). Based on selection rules, the fractional intensity of the emission line due to the decay to the state ($n = 3, l = 1$)

Topic – Atomic and molecular physics

Subtopic – Selection rule

- (a) $\frac{3}{4}$ (b) $\frac{1}{2}$ (c) $\frac{1}{4}$ (d) 0

Ans. : (a)

Q69. The volume of an optical cavity is 1 cm^3 . The number of modes it can support within a bandwidth of 0.1 nm , centered at $\lambda = 500 \text{ nm}$, is of the order of

Topic – Optics

Subtopic – Laser

- (a) 10^3 (b) 10^5 (c) 10^{10} (d) 10^7

Ans.: (c)

Solution: Number of Laser modes

$$N = 8\pi V \frac{\Delta\lambda}{\lambda^4} = 8\pi \times (10^{-2})^3 \times \frac{0.1 \times 10^{-9}}{(5 \times 10^{-7})^4} = 4.02 \times 10^{10}$$

Q70. Barium Titanate (BaTiO_3) crystal has a cubic perovskite structure, where the Ba^{2+} ions are at the vertices of a unit cube, the O^{2-} ions are at the centres of the faces while the Ti^{4+} is at the centre. The number of optical phonon modes of the crystal is

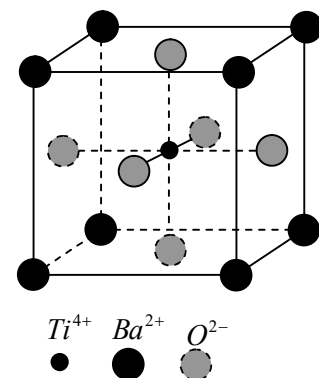

Topic – Solid state physics
Subtopic – Lattice vibration

- (a) 12 (b) 15
(c) 5 (d) 18

Ans.: (a)

Solution: Effective number of atoms per unit cell is

$$n_{eff} = \frac{1}{8} \times 8 + \frac{1}{2} \times 6 + 1 \times 1 = 1 + 3 + 1 = 5$$

Total degree of freedom $5 \times 3 = 15$

The number of Acoustical phonon modes = 3

The number of optical phonon modes $15 - 3 = 12$

Q71. The dispersion relation of optical phonons in a cubic crystal is given by $\omega(k) = \omega_0 - ak^2$ where ω_0 and a are positive constants. The contribution to the density of states due to these phonons with frequencies just below ω_0 is proportional to

Topic – Solid state physics
Subtopic – Density of state

- (a) $(\omega_0 - \omega)^{1/2}$ (b) $(\omega_0 - \omega)^{3/2}$ (c) $(\omega_0 - \omega)^2$ (d) $(\omega_0 - \omega)$

Ans.: (a)

Solution: $g(k) dk = \left(\frac{L}{2\pi}\right)^3 4\pi k^2 dk = \left(\frac{L}{2\pi}\right)^3 4\pi k - k dk$

Given $\omega = \omega_0 - ak^2 \Rightarrow k = \frac{1}{\sqrt{a}}(\omega_0 - \omega)^{1/2}$ and $d\omega = -2ak dk$

$$\therefore g(\omega) d\omega = \left(\frac{L}{2\pi}\right)^3 \frac{4\pi}{2a^{3/2}} (\omega_0 - \omega)^{1/2}$$

Thus, $\rho(\omega) \propto (\omega_0 - \omega)^{1/2}$

Q72. A silicon crystal is doped with phosphorus atoms. (The binding energy of a H atom is 13.6 eV, the dielectric constant of silicon is 12 and the effective mass of electrons in the crystal is $0.4 m_e$). The gap between the donor energy level and the bottom of the conduction band is nearest to

Topic – Solid state physics

Subtopic – Semiconductor physics

- (a) 0.01 eV (b) 0.08 eV (c) 0.02 eV (d) 0.04 eV

Ans.: (d)

Solution: $E_d = \frac{13.6}{\epsilon^2} \times \frac{M^*}{M_e} (eV)$

$$\therefore E_d = \frac{13.6}{(12)^2} \times 0.4 = 0.04 \text{ eV}$$

Q73. Assume that pion-nucleon scattering at low energies in which isospin is conserved is described by the effective interaction potential $V_{eff} = F(r) \vec{I}_\pi \cdot \vec{I}_N$, where $F(r)$ is a function of the radial separation r and \vec{I}_π and \vec{I}_N denote, respectively, the isospin vectors of a pion and the nucleon.

The ratio $\frac{\sigma_{I=3/2}}{\sigma_{I=1/2}}$ of the scattering cross-sections corresponding to total isospin $I = \frac{3}{2}$ and $\frac{1}{2}$ is

Topic – Atomic and molecular physics

Subtopic – Selection rule

- (a) $\frac{3}{2}$ (b) $\frac{1}{4}$ (c) $\frac{5}{4}$ (d) $\frac{1}{2}$

Ans.: (b)

Solution: $I_i = 2, \quad I_+ = 0$

Q74. A nucleus decays by the emission of a gamma ray from an excited state of spin parity 2^+ to the ground state with spin-parity 0^+ what is the type of the corresponding radiation?

Topic – Atomic and molecular physics

Subtopic – Transition rule

- (a) magnetic dipole (b) electric quadrupole
(c) electric dipole (d) magnetic quadrupole

Ans.: (b)

Solution: $L = 2$ and parity change

\therefore The transition is of electric quadrupole (E_2)

Q75. The low lying energy levels due to the vibrational excitations of an even-even nucleus are shown in the figure below.

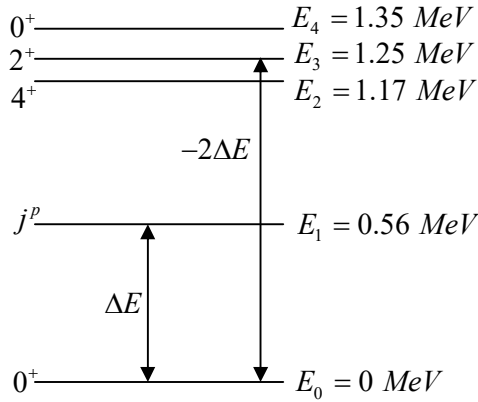

The spin-parity j^p of the level E_1 is

Topic – Atomic and molecular physics

Subtopic – Selection rule

- (a) 1^+ (b) 1^- (c) 2^- (d) 2^+

Ans.: (d)

Solution: Quadrupole oscillations are the lowest order nuclear vibrational mode. The quanta of vibrational energy are called phonons. A quadrupole phonon carries 2 units of angular momentum. Therefore, the parity is $P = (-1)^2 = +ve$

Also, the even-even ground state is 0^+ . The 1 phonon excited state is 2^+ . The 2 phonons excited states are $0^+, 2^+, 4^+$. Thus correct option is (a)

$1.35 \text{ MeV } 0^+$
 $1.25 \text{ MeV } 2^+$
 $1.17 \text{ MeV } 4^+$

} 2-phonons

$0.56 \text{ MeV } 2^+$: 1-phonon

$0 \text{ MeV } 0^+$: Ground state