

Section A

(for both Integrated M.Sc.--Ph.D. and Ph.D. candidates)

This Section consists of 25 questions. All are of multiple-choice type. Mark only one option on the online interface provided to you. If more than one option is marked, it will be assumed that the question has not been attempted. A correct answer will get +3 marks, an incorrect answer will get –1 mark.

1. Consider a square which can undergo rotations and reflections about its centre, where making no transformation at all is counted as a rotation by 0^0 . The total number of such distinct rotations and reflections which will keep the square unchanged is

- ✓ (a) 8 (b) 4
(c) 16 (d) 32

2. Consider the two-dimensional polar integral

$$P = \int dr d\theta r^{19} e^{-r^2} \sin^8 \theta \cos^{11} \theta$$

If the integration is over only the first quadrant ($0 \leq \theta \leq \pi/2$), the value of P is

- ✓ (a) 180 (b) 88π
(c) 20160 (d) 16π

3. Consider a set of three 3-dimensional vectors

$$A = \begin{pmatrix} 1 \\ 0 \\ 0 \end{pmatrix} \quad B = \begin{pmatrix} 0 \\ 1 \\ 0 \end{pmatrix} \quad C = \begin{pmatrix} 1 \\ 1 \\ 2 \end{pmatrix}$$

These vectors undergo a linear transformation

$$A \rightarrow A' = \mathbb{M}A \quad B \rightarrow B' = \mathbb{M}B \quad C \rightarrow C' = \mathbb{M}C$$

where \mathbb{M} is given by

$$\mathbb{M} = \begin{pmatrix} 1 & 1 & 4 \\ 1 & 0 & 1 \\ 2 & 1 & 1 \end{pmatrix}$$

The volume of a parallelepiped whose sides are given by the transformed vectors A' , B' and C' is

- ✓ (a) 8 (b) 4
(c) 2 (d) 16

4. A solid homogeneous sphere floats in water with a portion sticking out above the water, as shown in the figure below. The height of the highest point above the water surface is $R/2$ where R is the radius of the sphere.

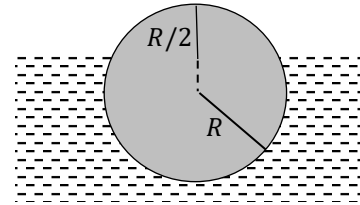

If the density of water is 1 g cm^{-3} , the density of the material (in g cm^{-3}) must be

- ✓ (a) $27/32$ (b) $5/32$
 (c) $13/18$ (d) $5/18$

5. A particle of mass m moves under the action of a central potential

$$V(r) = -\frac{e^2}{r}$$

where e is a constant. Two vectors which remain conserved during the motion are

- (i) the angular momentum $\vec{L} = \vec{r} \times \vec{p}$
 (ii) the Runge-Lenz vector $\vec{K} = \vec{p} \times \vec{L} - me^2\hat{r}$ (where $\hat{r} = \vec{r}/r$)

The conserved energy E of the particle can be written as

- ✓ (a) $\frac{K^2 - m^2e^4}{2mL^2}$ (b) $\frac{m^2e^4 - K^2}{2mL^2}$
 (c) $\frac{2mL^2}{K^2 - m^2e^4}$ (d) $\frac{2mL^2}{m^2e^4 - K^2}$

6. The Principle of Linear Superposition of electron states in quantum mechanics is nicely illustrated by the

- ✓ (a) Davisson-Germer experiment
 (b) Compton scattering experiment
 (c) Franck-Hertz experiment
 (d) Millikan oil-drop experiment

7. A particle moves in one dimension x under the influence of a potential $V(x)$ as sketched in the figure below. The shaded region corresponds to infinite V , i.e., the particle is not allowed to penetrate there.

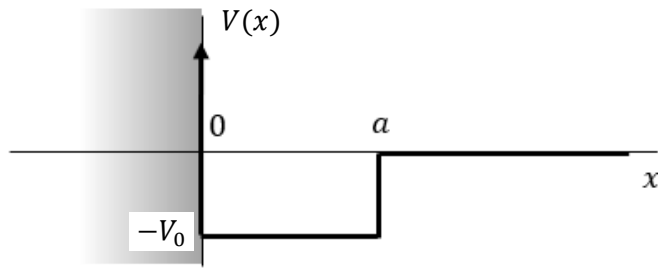

If there is an energy eigenvalue $E = 0$, then a and V_0 are related by

- ✓ (a) $a^2 V_0 = \frac{(n + \frac{1}{2})^2 \pi^2}{2m}$ (b) $a^2 V_0 = \frac{n^2 \pi^2}{2m}$
- (c) $a^2 V_0 = \frac{(n + \frac{1}{2}) \pi^2}{2m}$ (d) $a^2 V_0 = \frac{n \pi^2}{2m}$

8. In a hydrogenic atom of atomic number Z , the probability amplitude that the nucleus will capture an electron from its own K-shell is proportional to the overlap between the nuclear wave-function

$$\psi_n(\vec{r}) = \frac{1}{\sqrt{8\pi r_N^3}} e^{r/r_N}$$

and the electron wave-function

$$\psi_e(\vec{r}) = \frac{Z^{3/2}}{\sqrt{8\pi a_0^3}} e^{-Zr/a_0}$$

where a_0 is the Bohr radius and r_N is the nuclear radius, which is known to vary as $r_N \propto Z^{0.37}$. The probability of electron capture, to a very good approximation, will be proportional to Z^α where α is

- ✓ (a) 4.11 (b) 2.22
- (c) 2.05 (d) 1.11

9. Treat the hydrogen molecule H_2 as a rigid rotator. The next-to-largest wavelength in its rotational spectrum is about $111 \mu\text{m}$. From this it can be estimated that the separation between the pair of hydrogen atoms is about

- ✓ (a) 0.12 nm (b) 24.4 nm
- (c) 61.4 nm (d) $3.07 \mu\text{m}$

10. A falling raindrop, spherical in shape, with a diameter of $1\ \mu\text{m}$, acquires a uniform negative charge due to friction with air. The electric field at a distance of $10\ \mu\text{m}$ from the surface of the droplet is measured to be $101\ \text{V m}^{-1}$.

The number of excess electrons acquired by the droplet is

- ✓ (a) 7 (b) 7.02×10^6
(c) 1.4×10^{23} (d) 1414

11. An electromagnet is made by winding N turns of wire around a wooden cylinder of diameter d and passing a current I through it. When the current flows, a magnetic field of magnitude B is produced at a perpendicular distance z_0 from the axis of the cylinder, where $z_0 \gg d$.

If the number of turns N , the diameter of the wooden cylinder d and the current I are all doubled, then the magnitude of the magnetic field will be $B/2$ at a distance $z =$

- ✓ (a) $3.2 z_0$ (b) $0.5 z_0$
(c) $4.8 z_0$ (d) $2.4 z_0$

12. If an electron is set into oscillatory motion by the electric field of a laser of intensity $150\ \text{W m}^{-2}$ and wavelength $554\ \text{nm}$, the amplitudes of its displacement and velocity, respectively, are expected to be

- ✓ (a) $5.1 \times 10^{-18}\ \text{m}$,
 $1.7 \times 10^{-2}\ \text{m s}^{-1}$ (b) $3.4 \times 10^{-17}\ \text{m}$,
 $1.0 \times 10^{-1}\ \text{m s}^{-1}$
(c) $3.4 \times 10^{-16}\ \text{m}$,
 $1.7 \times 10^{-1}\ \text{m s}^{-1}$ (d) $3.4 \times 10^{-18}\ \text{m}$,
 $1.7 \times 10^{-2}\ \text{m s}^{-1}$

13. A bicycle tyre is pumped with air to an internal pressure of $6\ \text{atm}$ at 20°C , at which point it suddenly bursts. Assuming the external pressure to be $1\ \text{atmosphere}$ and the subsequent sudden expansion to be adiabatic, the temperature immediately after the burst is approximately

- ✓ (a) -97.5°C (b) -108.5°C
(c) 45.5°C (d) 216.0°C

14. A vertical cylinder of height H is filled with an ideal gas of classical point particles each of mass m and is allowed to come to equilibrium under gravity at a temperature T . The mean height of these particles is

✓ (a) $\frac{k_B T}{mg} \left(1 - \frac{mgH/k_B T}{e^{mgH/k_B T} - 1} \right)$ (b) $\frac{H}{3} \frac{mgH/k_B T}{e^{mgH/k_B T} + 1}$

(c) $\frac{k_B T}{mg} \left(1 - \frac{2mgH/k_B T}{e^{mgH/k_B T} + 1} \right)$ (d) $\frac{H}{3} \frac{mgH/k_B T}{e^{mgH/k_B T} - 1}$

15. Two students A and B, measure the time period of a simple pendulum in the laboratory using the same stopwatch but following two different methods.

- Student A measures the time taken for one oscillation and repeats it for N_A number of times and finds the average.
- Student B, on the other hand, measures the time taken for N_B number of oscillations and then computes the period.

Given that $N_A, N_B \gg 1$, to ensure that both students measure the time period with the same uncertainty, the relation between N_A and N_B must be

✓ (a) $N_A = N_B^2$ (b) $N_A = \sqrt{N_B}$

(c) $N_A = N_B$ (d) $\ln 2 N_A = N_B$

16. A commercial advertisement for a solar power converter claims that when the temperature of the plate (area 1.6 m^2) absorbing 20% of the solar energy (solar constant is about $1.36 \text{ kW m}^{-2} \text{ s}^{-1}$) reaches 127° C and the rest of the device is at room temperature (27° C), the system will deliver a power of 100 W.

If a prospective customer comes to you for advice about buying this device, your advice should be that

- ✓ (a) it is an efficient device for the given specifications.
- (b) the power delivered is very small for the given specifications.
- (c) the advertisement is false and the device cannot deliver so much power.
- (d) other similar devices are available which can deliver 1.5 – 2.0 times the power with the same specifications.

17. Since the refractive index of water is $4/3$, the angular velocity (in degrees per hour) of the Sun at noon is perceived by a fish in the ocean deep below the surface as around

- ✓ (a) 11.3 (b) 15.0
(c) 13.2 (d) 20.0

18. The circuit diagram on the right shows a block A representing a cubic structure comprising 12 identical resistances of $120\ \Omega$ each, whose body diagonal vertices are connected to the rest of the circuit with an inductor $L = 10\ \text{mH}$, a resistor $R = 100\ \Omega$, and a capacitor $C = 1\ \mu\text{F}$.

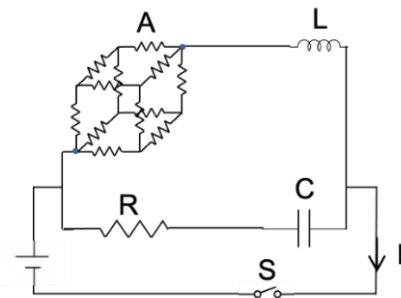

Now, the switch S is turned on at $t = 0$. The earliest time at which the current reaches a steady value I_0 is

- ✓ (a) zero (b) $100\ \mu\text{s}$
(c) $200\ \mu\text{s}$ (d) infinite

19. Consider a circuit with an operational amplifier (op amp) and four resistors as sketched below.

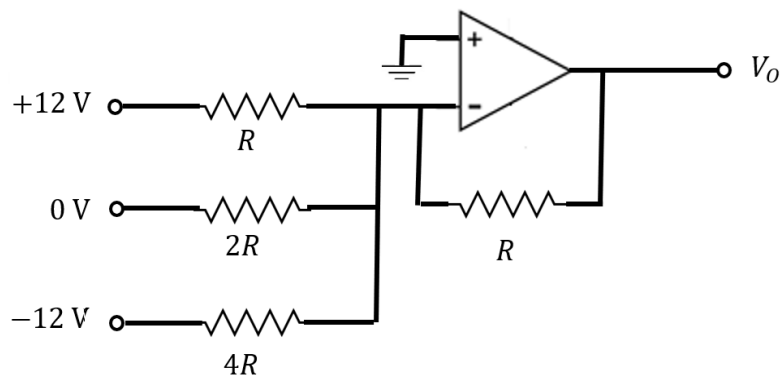

The output voltage V_o is

- ✓ (a) $-9\ \text{V}$ (b) $0\ \text{V}$
(c) $-12\ \text{V}$ (d) $-6\ \text{V}$

20. It is required to design a circuit with an impedance $Z(\omega)$ such that

$$Z(\omega) = ik(\omega - \omega_0)$$

for a range of frequencies ω such that

$$|\omega - \omega_0|/\omega_0 \ll 1$$

where k and ω_0 are constant real numbers.

A possible design for this circuit would correspond to

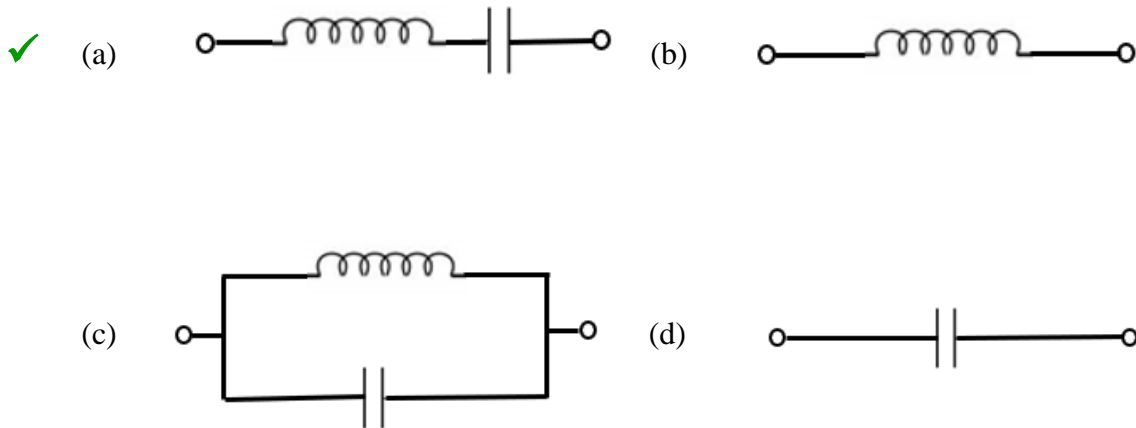

21. On a wet monsoon day at 12 noon, a thin film of oil of thickness $0.3 \mu\text{m}$ is formed on a wet road. If the refractive index of oil and water are 1.475 and 1.333, respectively, which of the following wavelengths of light will be reflected with maximum intensity?

- ✓ (a) 590 nm (b) 407 nm
(c) 443 nm (d) 640 nm

22. A gas of atoms, each of mass m , in thermal equilibrium at a temperature T , is radiating with a frequency ν_0 . The Doppler broadening (full width at half maximum, or FWHM) of the observed spectral line would be given by

- ✓ (a) $\frac{2\nu_0}{c} \sqrt{\frac{2 \ln 2 k_B T}{m}}$ (b) $\frac{\nu_0}{c} \sqrt{\frac{2k_B T}{m}}$
(c) $\frac{2\nu_0}{c} \sqrt{\frac{\ln 2 k_B T}{m}}$ (d) $\frac{2\nu_0}{c} \sqrt{\frac{2k_B T}{m}}$

23. Two particles, as specified in the table below, both enter a region of uniform magnetic field in a direction perpendicular to the field direction.

Particle	Rest Mass	Kinetic Energy
Alpha	3.7 GeV	11.2 GeV
Deuteron	1.9 GeV	20.0 MeV

If both the particles then follow circular trajectories in the magnetic field, the ratio of their time periods for one full revolution must be

- ✓ (a) 4.0 (b) 3.0
(c) 2.0 (d) 1.0

24. Natural potassium contains a radioactive component of ^{40}K that has two decay modes.
- In the first mode, ^{40}K undergoes a β decay to the ground state of ^{40}Ca .
 - In the second mode, ^{40}K undergoes an electron capture to the excited state of ^{40}Ar , followed by a single γ transition to the ground state of ^{40}Ar .

The amount of radioactive ^{40}K in a natural potassium (atomic weight of 39.089) sample is known to be 0.0118 percent. It is also known that in the decay of ^{40}K , for every 100 β particles emitted, there number of γ -photons emitted is 12.

If the number of β -particles emitted per second by 1 kg of natural potassium is 2.7×10^4 , the mean lifetime of ^{40}K in years is

- ✓ (a) 1.9×10^9 (b) 1.3×10^9
(c) 1.7×10^9 (d) 1.1×10^8

25. The free electron model of metals (Drude model) explains several physical properties, but cannot be used to explain

- ✓ (a) positive value of Hall coefficient
(b) magnetic susceptibility of the metal
(c) electrical conductivity of the metal
(d) thermal conductivity of the metal

Section B

(only for Integrated M.Sc.-Ph.D. candidates)

This Section consists of 15 questions. All are of multiple-choice type. Mark only one option on the online interface provided to you. If more than one option is marked, it will be assumed that the question has not been attempted. A correct answer will get +5 marks, an incorrect answer will get 0 mark.

26. The value of the integral

$$\int_{-\pi/2}^{+\pi/2} dx \cosh kx^2 \sin^2 x$$

in the large- k limit, will be

- ✓ (a) $\frac{1}{k\pi} e^{k\pi^2/4}$ (b) $\cosh\left(\frac{\pi^2}{4}\right)$
- (c) $\frac{1}{k^2\pi^2} \cosh\left(\frac{\pi^2}{4}\right)$ (d) $\frac{1}{2k\pi} e^{k\pi^2/4}$

27. A hollow metal sphere filled with a thick, highly viscous oil is rotating about a vertical axis with an initial angular velocity ω_0 . However, there is a small hole at the bottom of this sphere, through which drops of oil are leaking out vertically at a steady rate. The variation of the angular velocity $\omega(t)$ of the sphere with time t is best represented graphically by

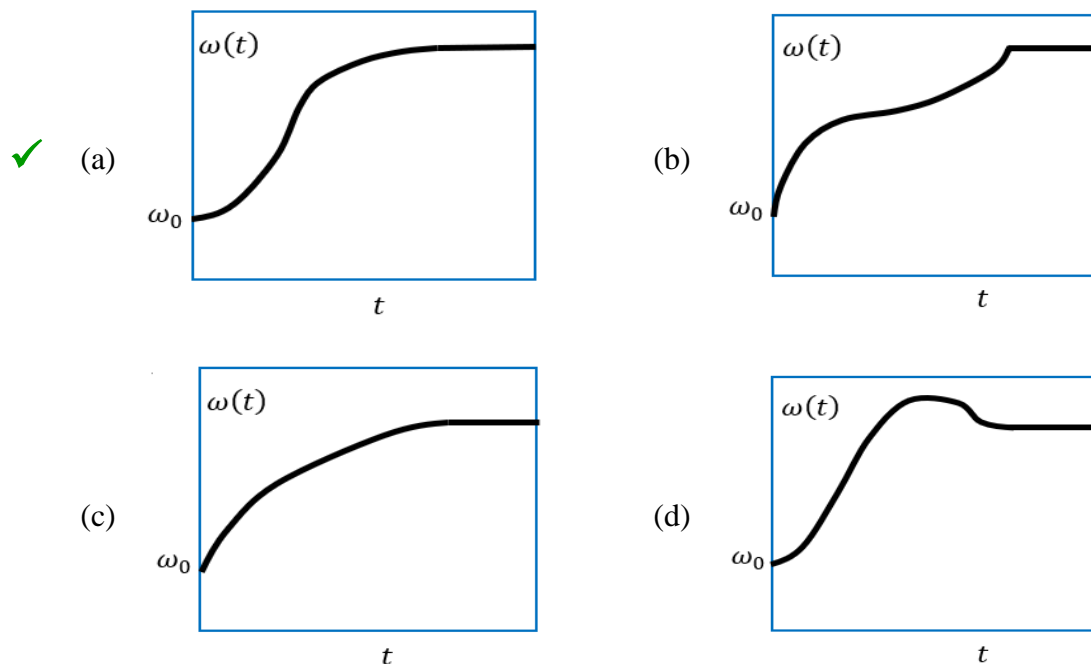

28. A pendulum which is suspended from the ceiling of a train has time period T_0 when the train is stationary. When the train moves with a small but steady speed v around a horizontal circular track of radius R , the time period of the pendulum will be

- ✓ (a) $T_0 \left(1 - \frac{v^2 T_0^2}{4\pi^2 R}\right)^{-1/2}$ (b) $T_0 \left(1 + \frac{v^2 T_0^2}{4\pi^2 R}\right)^{-1/2}$
 (c) $T_0 \left(1 - \frac{v^4}{g^2 R^2}\right)^{1/4}$ (d) $T_0 \left(1 + \frac{v^4}{g^2 R^2}\right)^{1/4}$

29. A cricket ball, bowled by a fast bowler, rises from the pitch at an angle of 30° with a speed of 72 km/hr, then moves straight ahead and, at a height of 0.5 m, strikes the flat surface of the bat held firmly at rest in a horizontal position (see figure). As a result, the ball bounces off elastically, providing a return catch straight back to the bowler.

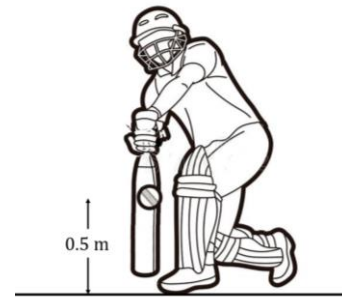

If the coefficient of restitution between the bat and the ball is 0.577, the acceleration due to gravity is 10 m s^{-2} and air resistance can be neglected, the catch will carry, before hitting the ground, to a distance of approximately

- ✓ (a) 19.5 m (b) 37.0 m
 (c) 9.5 m (d) 21.0 m

30. In a matrix mechanics formulation, a spin-1 particle has angular momentum components

$$L_x = \frac{\hbar}{2} \begin{pmatrix} 0 & 1 & -1 \\ 1 & \sqrt{2} & 0 \\ -1 & 0 & -\sqrt{2} \end{pmatrix} \quad L_z = \frac{\hbar}{2} \begin{pmatrix} 2 & 0 & 0 \\ 0 & -1 & -1 \\ 0 & -1 & -1 \end{pmatrix}$$

It follows that $L_y =$

- ✓ (a) $\frac{\hbar}{2} \begin{pmatrix} 0 & -i & i \\ i & 0 & -i\sqrt{2} \\ -i & i\sqrt{2} & 0 \end{pmatrix}$ (b) $\frac{\hbar}{2} \begin{pmatrix} 0 & i & -i \\ -i & 0 & i\sqrt{2} \\ i & -i\sqrt{2} & 0 \end{pmatrix}$
 (c) $\sqrt{2} \hbar \begin{pmatrix} 0 & \sqrt{2} & 0 \\ \sqrt{2} & 1 & 0 \\ 0 & 0 & -1 \end{pmatrix}$ (d) $\sqrt{2} \hbar \begin{pmatrix} 0 & -\sqrt{2} & 0 \\ -\sqrt{2} & -1 & 0 \\ 0 & 0 & 1 \end{pmatrix}$

- 31 Two equal positive point charges $Q = +1$ are placed on either side of an x -axis normal to a grounded infinite conducting plane at distances of $x = +2$ units and $x = -1$ unit respectively (see figure) w.r.t. the point of intersection of the axis with the conducting plane as origin.

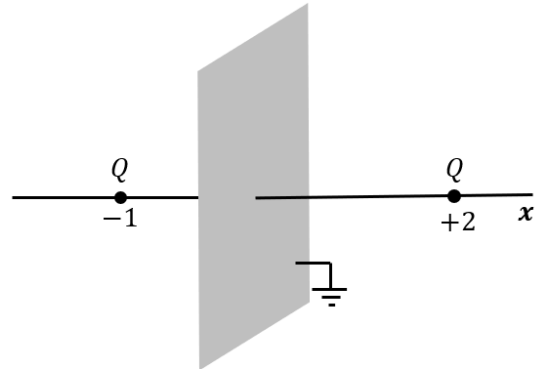

The electrostatic potential along the axis will correspond to the graph in

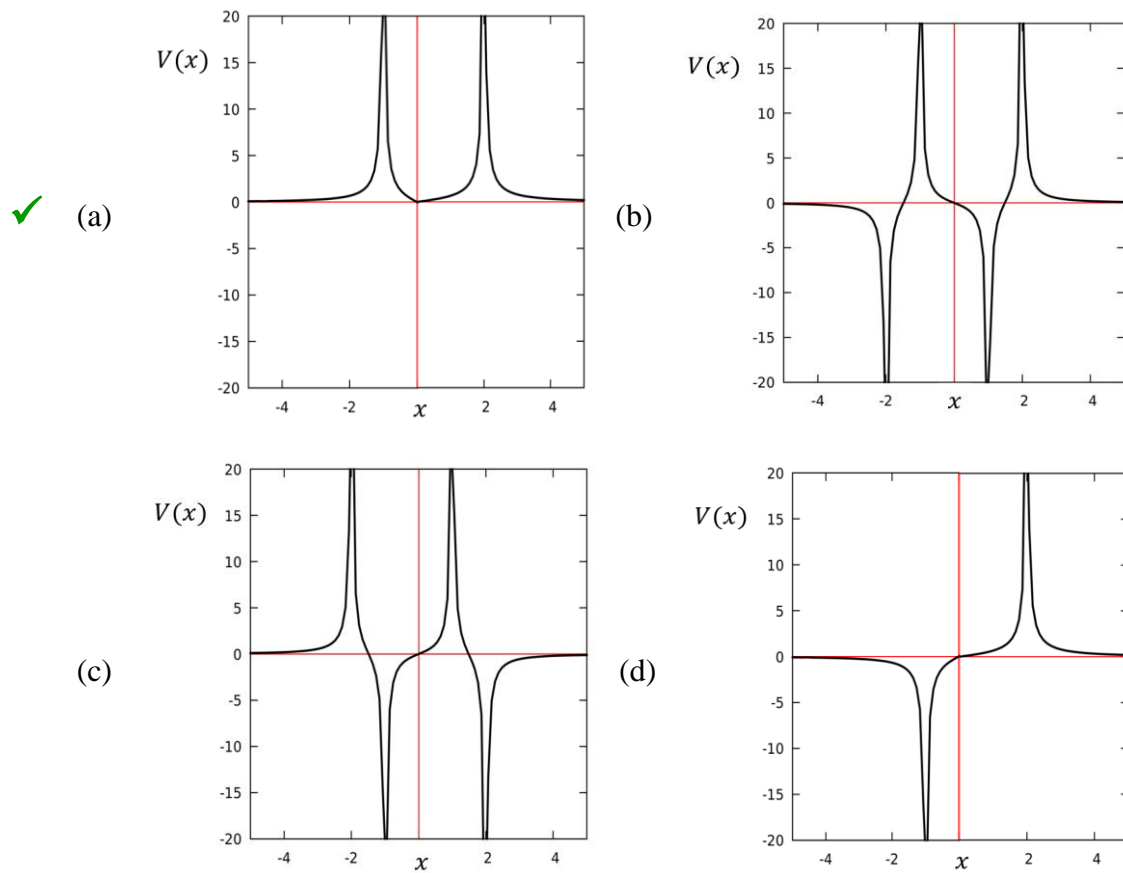

32. Two co-axial solenoids A and B, one placed completely inside the other, have the following parameters:

Solenoid	No of turns	Length	Diameter
A	1000	50 cm	2 cm
B	2000	50 cm	4 cm

The mutual inductance between the solenoids is

- ✓ (a) 1.58 mH (b) 125.7 mH
(c) 395.0 mH (d) 12.57 mH

33. A particle of mass m in a three-dimensional potential well has a Hamiltonian of the form

$$H = \frac{p_x^2}{2m} + \frac{p_y^2}{2m} + \frac{p_z^2}{2m} + \frac{1}{2}m\omega^2x^2 + \frac{1}{2}m\omega^2y^2 + 2m\omega^2z^2$$

where ω is a constant. If there are two identical spin- $1/2$ particles in this potential having a total energy

$$E = 6\hbar\omega$$

the entropy of the system will be

- ✓ (a) $k_B \ln 14$ (b) $k_B \ln 16$
 (c) $k_B \ln 12$ (d) $k_B \ln 10$

34. A quantum dot is constructed such that it has just three energy levels, with energies E , $2E$ and $3E$ respectively. The chemical potential in the system has the value $\mu = 2E$ and the temperature is given by

$$T = \frac{E}{2k_B}$$

The expected number of electrons populating the quantum dot will be

- ✓ (a) 3.0 (b) 2.5
 (c) 1.5 (d) 4.0

35. The non-inverting amplifier shown in the figure on the right is constructed using a non-ideal operational amplified (op amp) with a *finite* open loop gain A .

The value of feedback fraction is

$$B = \frac{R_2}{R_1 + R_2} = 0.1$$

If the gain A varies such that

$$10^4 < A < 10^5$$

then the approximate percentage variation in the closed loop gain will be.

- ✓ (a) 0.09 % (b) 0.0 %
 (c) 0.9 % (d) 9.0 %

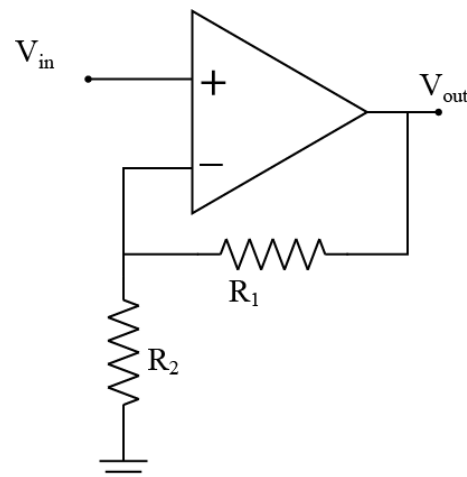

36. In a standardized entrance exam, the passing rates for the past 10 years are tabulated below.

Year	2011	2012	2013	2014	2015	2016	2017	2018	2019	2020
Passing Rate	22 %	16 %	23 %	21%	22 %	14 %	17 %	20 %	24 %	21 %

If 1000 candidates appear for the exam every year, the probability that more than 250 students will pass the exam this year is about

- ✓ (a) 6% (b) 20%
- (c) 25% (d) 0.1%

37. A spectrographic method to search for exoplanets is by measuring its velocity along the line of sight, using the Doppler shift in the spectrum. If a star of mass M and a planet of mass m are moving around their common centre of mass, this component of velocity will vary periodically with an amplitude.

$$A = \left(\frac{2\pi G_N}{T} \right)^{1/3} \frac{m}{M^{2/3}}$$

For a particular planet-star system, if the time period is $T = (12 \pm 0.3)$ years, and A and M are measured with an accuracy of 3% each, then the error in the measurement of the mass m is

- ✓ (a) 3.7 % (b) 8.5 %
- (c) 5.8 % (d) 6.3%

38. A satellite used to make Google Earth images carries on board a telescope which must be designed, when operating at a wavelength λ , to be able to resolve objects on the ground of length as small as δ .

If the satellite goes around the Earth in a circular orbit with uniform speed v , the minimum diameter D_{\min} of the telescope mirror can be determined in terms of R , the radius of the Earth, and g , the acceleration due to gravity at the surface, to be

- ✓ (a) $\frac{1.22\lambda}{\delta} \left(\frac{gR^2}{v^2} - R \right)$ (b) $\frac{1.22\lambda}{\delta} \frac{gR^2}{v^2} \left(1 + \frac{R}{\lambda} \right)$
- (c) $\frac{1.22\lambda}{\delta} \frac{gR^2}{\lambda v^2}$ (d) $\frac{1.22\lambda}{\delta} \sqrt{\frac{gR^3}{v^2}}$

39. An observer O, moving with relativistic speed v away from a fixed plane mirror M in a line perpendicular to the mirror surface, sends a pulse of light of wavelength λ towards the mirror.



The wavelength of the light reflected back to the observer will be

- ✓ (a) $\lambda \left(\frac{c+v}{c-v} \right)$ (b) $\lambda \left(\frac{c+2v}{c-2v} \right)$
 (c) $\lambda \sqrt{\frac{c-v}{c+v}}$ (d) $\lambda \left(\frac{c-2v}{c+2v} \right)$

40. The low-temperature specific heat of a certain material is primarily due to acoustic phonons. The frequency ω of a phonon is related to its wavevector k by $\omega = ck$, where c is the speed of sound in the material. The phonons have a Bose distribution

$$n(k) = \frac{1}{e^{\hbar ck/k_B T} - 1}$$

and the energy of a phonon has a maximum possible value ω_D .

In a two-dimensional sample, the specific heat at low-temperatures behaves as

- ✓ (a) $\left(\frac{T}{\omega_D} \right)^2$ (b) $\left(\frac{T}{\omega_D} \right)^3$
 (c) $\left(\frac{T}{\omega_D} \right)^{3/2}$ (d) $\frac{T}{\omega_D}$

28. A system with two generalized coordinates (q_1, q_2) is described by the Lagrangian

$$L = m \left(\dot{q}_1^2 + 2\dot{q}_1\dot{q}_2 + \frac{3}{2} \dot{q}_2^2 \right) - k \left(\frac{3}{2} q_1^2 + 2q_1q_2 + q_2^2 \right)$$

where m is the mass, and k is a constant.

This system can execute oscillations with two possible time periods

- ✓ (a) $T = 2\pi \sqrt{\frac{2m}{k}}$ and $T = 2\pi \sqrt{\frac{m}{2k}}$
- (b) $T = 2\pi \sqrt{\frac{m}{2k}(5 - 2\sqrt{6})}$ and $T = 2\pi \sqrt{\frac{m}{2k}(5 + 2\sqrt{6})}$
- (c) $T = \pi \sqrt{\frac{m}{k}(1 - \sqrt{15})}$ and $T = \pi \sqrt{\frac{m}{k}(1 + \sqrt{15})}$
- (d) $T = 2\pi \sqrt{\frac{2m}{3k}}$ and $T = 2\pi \sqrt{\frac{3m}{2k}}$

29. A system was formed of three spin- $\frac{1}{2}$ particles A, B and C, respectively and it was prepared in an initial state

$$|\psi\rangle = c_1|\uparrow\uparrow\uparrow\rangle + c_2|\uparrow\uparrow\downarrow\rangle + c_3|\uparrow\downarrow\uparrow\rangle + c_4|\uparrow\downarrow\downarrow\rangle + c_5|\downarrow\uparrow\uparrow\rangle + c_6|\downarrow\uparrow\downarrow\rangle + c_7|\downarrow\downarrow\uparrow\rangle + c_8|\downarrow\downarrow\downarrow\rangle$$

where the symbols $|\uparrow\rangle$ and $|\downarrow\rangle$ indicate states with $S_z = +\frac{1}{2}$ (spin-up) and $S_z = -\frac{1}{2}$ (spin-down) respectively.

A measurement was made on the system in the initial state and this identified the spin state of the particle A to be $|\downarrow\rangle$ (spin-down). Now the expectation value of $\langle S_z \rangle$ for the particle C could be calculated as

- ✓ (a) $\frac{|c_5|^2 + |c_7|^2 - |c_6|^2 - |c_8|^2}{|c_5|^2 + |c_7|^2 + |c_6|^2 + |c_8|^2}$
- (b) $\frac{c_5 + c_7 - c_6 - c_8}{|c_5|^2 + |c_7|^2 + |c_6|^2 + |c_8|^2}$
- (c) $\frac{(c_5^* + c_7^* - c_6^* - c_8^*)(c_5 + c_7 - c_6 - c_8)}{|c_5|^2 + |c_7|^2 + |c_6|^2 + |c_8|^2}$
- (d) $\frac{(c_5 + c_7)^*(c_5 + c_7) - (c_6 + c_8)^*(c_6 + c_8)}{|c_5|^2 + |c_7|^2 + |c_6|^2 + |c_8|^2}$

30. A particle is confined to a one-dimensional lattice with a lattice spacing δ . In the position space, the Hamiltonian operator for this particle is given by the matrix

$$\mathcal{H} = E_0 \begin{pmatrix} \ddots & & & & & & & \\ & \dots & \dots & 0 & 0 & 0 & 0 & \\ & \dots & 2 & -1 & 0 & 0 & 0 & \\ & 0 & -1 & 2 & -1 & 0 & 0 & \\ & 0 & 0 & -1 & 2 & -1 & 0 & \\ & 0 & 0 & 0 & -1 & 2 & \dots & \\ & 0 & 0 & 0 & 0 & \dots & \dots & \ddots \end{pmatrix}$$

Noting that it commutes with the generator T of translations

$$\mathcal{T} = \begin{pmatrix} \ddots & & & & & & & \\ & \dots & \dots & 0 & 0 & 0 & 0 & \\ & \dots & 0 & 1 & 0 & 0 & 0 & \\ & 0 & 0 & 0 & 1 & 0 & 0 & \\ & 0 & 0 & 0 & 0 & 1 & 0 & \\ & 0 & 0 & 0 & 0 & 0 & \dots & \\ & 0 & 0 & 0 & 0 & \dots & \dots & \ddots \end{pmatrix}$$

where $T = e^{i\mathcal{P}\delta/\hbar}$ in terms of the momentum operator \mathcal{P} , the energy of a state with momentum p will be

- ✓ (a) $4E_0 \sin^2(p\delta/2\hbar)$ (b) $E_0 \cos(p\delta/\hbar)$
 (c) $E_0 \sin(p\delta/\hbar)$ (d) $E_0 (p\delta/2\hbar)^2$

31. According to a standard table, the refractive index of water at 4°C is 1.33 at a wavelength of 590 nm. However, a carefully performed experiment in the lab yielded a refractive index of 1.41.

Which one of the following statements could be the explanation of this discrepancy?

- ✓ (a) The experiment was performed at a wavelength lower than 590 nm.
 (b) The experiment was performed at a wavelength higher than 590 nm.
 (c) The water sample was at a temperature lower than 4°C.
 (d) The water sample was at a temperature much higher than 4°C.

32. The power radiated by a point charge q moving rapidly with a uniform speed v in a circle of radius R will be

- ✓ (a) $\frac{q^2 c}{6\pi\epsilon_0 R^2} \left(\frac{v^2}{c^2 - v^2}\right)^2$ (b) $\frac{q^4 c^2}{6\pi\epsilon_0 R^2} \left(\frac{v^2}{c^2 - v^2}\right)^2$
 (c) $\frac{q^3 c}{6\pi\epsilon_0 R^4} \frac{v^2}{c^2 - v^2}$ (d) $\frac{q^2 c^3}{6\pi\epsilon_0 R^3} \frac{v^2}{c^2 - v^2}$

33. A pseudo-potential V_{12} between every pair of particles in an ideal gas is to be constructed which will reproduce the effects of quantum statistics if the gas particles are bosonic in nature. A correct formula for this, in terms of the inter-particle distance r_{12} and a mean distance λ , will be of the form

- ✓ (a) $V_{12} = -k_B T \ln (1 + e^{-2\pi r_{12}^2 / \lambda^2})$
 (b) $V_{12} = -k_B T \ln (1 - e^{-2\pi r_{12}^2 / \lambda^2})$
 (c) $V_{12} = +k_B T \ln (1 + e^{-2\pi r_{12}^2 / \lambda^2})$
 (d) $V_{12} = +k_B T \ln (1 - e^{-2\pi r_{12}^2 / \lambda^2})$

34. Three students A, B and C are given identical counters and each is asked to measure the number of gamma rays emitted per second by a given radioactive source. They are expected to perform the counting many times and find the mean and the standard deviation. The students find the following:

Student	A	B	C
Measurement (counts/second)	482 ± 22	495 ± 10	501 ± 22

If a counting experiment conducted previously by the instructor on this same sample with another identical counter had recorded exactly 30,000 gamma rays in a minute, then which of the following interpretations is valid?

- ✓ (a) The measurement by student B is too precise to be believable.
 (b) The measurement of student B is more correct than that of student A.
 (c) The measurements of A and C have too large standard deviations.
 (d) The measurement of C is much more precise than that of A.

35. A thyratron consists of a tube filled with Xenon gas which can be used as a high-power electrical switch. Electrons are emitted from a cathode K heated by a filament F, and made to accelerate to some energy E by a voltage V applied across the anode plate P.

Electrons that scatter from the Xe atoms get deviated from their path and hit the shield S, which is a conducting envelope that transports the electrons back to ground potential (see figure on the right). The rest of the electrons strike the plate and contribute to the plate current i_p .

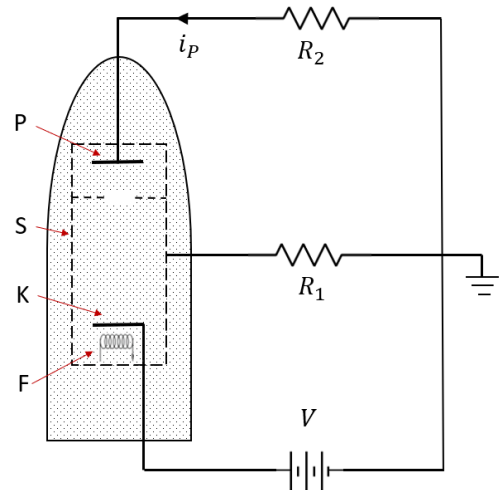

Which of the following graphs of the variation of the plate current i_p with increase in the accelerating voltage V could indicate the wave nature of the electron ?

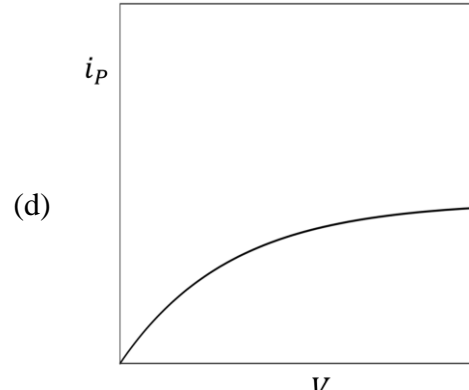
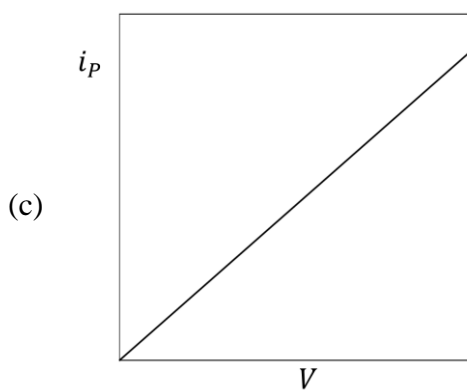
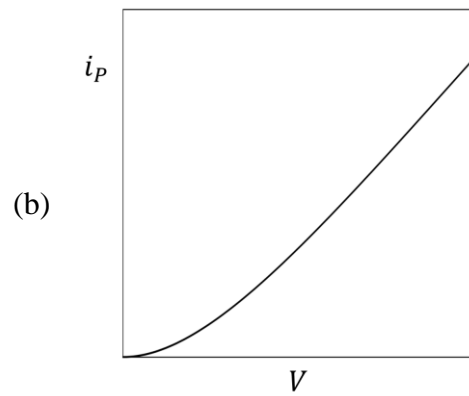
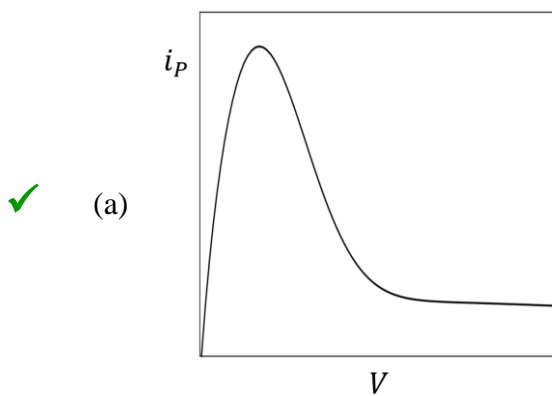

36. In a semiclassical approach, the Hamiltonian of a He atom is modified by adding a magnetic interaction term between the two electrons, of the form

$$\mathcal{H}_I = A_2 \vec{S}_1 \cdot \vec{S}_2$$

where \vec{S}_1 and \vec{S}_2 are the electron spins and A_2 is a coupling constant. This leads, for the configuration $1s^2$, to the energy shift

- ✓ (a) $-3A_2/4$ (b) $+3A_2/4$
(c) $+A_2/4$ (d) $-A_2/4$

37. In the shell model of the nucleus, it is known that orbitals get filled in the order

$$1s_{1/2} \quad 1p_{3/2} \quad 1p_{1/2} \quad 1d_{5/2} \quad 2s_{1/2} \quad 1d_{3/2} \quad \text{and so on}$$

For a nucleus of $^{18}_8\text{O}$ the two neutrons outside the doubly-magic core of $^{16}_8\text{O}$ will occupy the same orbital. The allowed value of J^P will be

- ✓ (a) 4^+ (b) 5^+
(c) 2^- (d) 3^+

38. From the knowledge that you already have about the length of one year and the fact that the Sun subtends 0.5° in the sky, the average density of the Sun can be computed in $\text{kg}\cdot\text{m}^{-3}$ as

- ✓ (a) 1.7×10^3 (b) 7.5×10^3
(c) 1.7×10^2 (d) 7.5×10^2

39. At very low temperatures, the electrical resistivity of most metals is dominated by

- ✓ (a) collisions of conduction electrons with impurity atoms and lattice vacancies.
(b) absorption of conduction electrons by ions in the lattice.
(c) collisions of conduction electrons with lattice phonons.
(d) transfer of conduction electrons to the valence band.

40. There are two conceivable channels by which a vector ρ^0 meson can decay into a pair of pseudoscalar pions. These are

$$\rho^0 \rightarrow \pi^0 + \pi^0 \quad \text{and} \quad \rho^0 \rightarrow \pi^+ + \pi^-$$

The probability that the decay takes place through the process $\rho^0 \rightarrow \pi^+ + \pi^-$ is approximately

- ✓ (a) 1
(b) $m_{\pi^0}/2m_{\pi^+}$
(c) $m_{\pi^+}^2/m_\rho^2$
(d) zero